

UDC 687.016:658.512

DOI: 10.15587/1729-4061.2018.148984

DEVELOPMENT OF A TECHNOLOGY FOR INTERACTIVE DESIGN OF GARMENTS USING ADD-ONS OF A VIRTUAL MANNEQUIN

A. Slavinska

Doctor of Technical Sciences, Professor*

E-mail: tksv@khnu.km.ua

O. Syrotenko

PhD, Associate Professor*

E-mail: sirotenko@email.ua

O. Zakharkovich

PhD, Associate Professor*

E-mail: zbir_vukladach@ukr.net

S. Kuleshova

PhD, Associate Professor*

E-mail: kuleshova_lana@ukr.net

*Department of technology and design of garments
Khmelnytskyi National University
Instytyska str., 11,
Khmelnytskyi, Ukraine, 29016

Досліджена проблема розробки технології інтерактивно-го конструювання одягу інженерними методами, що дозволяє застосувати пасивний режим автоматизованого проектування конструкторської документації. Теоретичною передумовою модульних підходів до формалізації проектування конструкцій одягу є сформульовані принципи координації дій в алгоритмах перетворення множини об'єкта дослідження. Технологія побудови геометричної моделі об'єкта представлена трьома видами інформаційних моделей: цифрова, сітчаста, поверхнева. В результаті аналітичних та експериментальних досліджень обґрунтовано алгоритм проектних ситуацій здійснення перетворень поверхні вихідного об'єкту, яким виступає електронний манекен, в конструкцію виробу.

Теоретично обґрунтовано вихідну базу даних для побудови та модифікації каркасних 3D-моделей манекенів, з метою забезпечення достовірності їх візуалізації.

Досліджено механізм інтерактивного модифікування оболонок поверхні одягу в циклі його силуетної деформації та побудови плоских розгортки одягу адаптованих до векторів модифікування ділянок поверхні манекена, для отримання конструкцій виробів ідентичних оригіналу морфологічної структури тіла споживача.

Запропоновано 4 сценарії проектних ситуацій відтворення та трансформації 3D-моделі силуетної поверхні манекена та виробу за оптимальним маршрутом, для підвищення швидкості та якості процесів комп'ютерного конструювання деталей одягу на фігури типової та нетипової тілобудови.

Апарат побудови зображень цифрової моделі тривимірного об'єкта враховує топологію геометричної структури форми та морфологічне поле синергетичних зв'язків елементів в процесах переходу від 3D до 2D проектування.

Сценарій адаптації силуетних 3D зображень виробу до модифікованих 2D конструкторських документів на засадах верифікації бази даних. Оцінку ефективності технології конструювання швейних виробів виконано за кількістю ітерацій проектних операцій в проектних процедурах з перевіркою рівня якості

Ключові слова: математична модель, 3D манекен, 2D розгортка одягу, деформація поверхні, силуетна трансформація, моделюючий ефект, універсальна конструкція

1. Introduction

A geometrical object in the practice of design and technological preparation of garment is as a flat sweep of a detail, subject to the interpretation into various types of design documents that themselves are carriers of key information.

The technical design of the templates of working documentation is focused on two-dimensional drawings for cutting and manufacturing the garment. The construction of templates is historically based on the following algorithms: construction of basic structures by the specified dimensional features, modification of model features of the garment, construction of a set of tailor patterns taking into account the package of materials.

Design documentation of the support of engineering solutions of an object is nowadays used in the digital format even at small enterprises with the frequent change of assortment. However, the conservatism of modern garment design holds back the use of the scientific and technical potential of computer systems for the tasks of adaptation of the geo-

metric information about an object in 3D transformations of a document into a 2D document.

The radical changes in engineering of clothing design, associated with the development of frame models of electronic mannequins, do not meet innovative expectations. This is explained by the insufficient accuracy of discrete anthropological characteristics of typical figures, the lack of substantiation of synergetic relations with the shape of a garment, the application of archiving obsolete basic designs.

Taken this into account, the relevant problem is the development of new principles of the technology of interactive designing of clothing by engineering techniques by means of the graphic adaptation of the object design to the morphological structure of a design document with the use of computer technologies.

2. Literature review and problem statement

In the second decade of the 21st century, several new approaches to modernization of clothing designing processes

based on 3D technologies were formed. The concept of combining the methods of 2D and 3D designing of clothing of different volume shapes contains the algorithms for the graphical information interpretation to select the best option of a virtual object [1]. The effectiveness of virtual modeling is determined by the concept of a typical project based on the expansion of the area of competitive application in the fashion industry [2]. The application of the virtual fitting method [3] increases the effectiveness of evaluation of 3D-modeling quality in the interactive process of clothes fitting without any losses of the identity of the original under conditions of regarmentation of an actual body [4].

The use of a mannequin as a prototype of a typical figure is explored in the processes of discrete modeling of the structural elements of a 3D-object based on a digital model. The anthropometric database of a digital model contains the coordinates of the points of matrix description of the elements of a frame [5].

The process of construction of a virtual 3D model of clothing is based on the use of increments of design body tolerances for modeling the shell of a silhouette shape. In papers [6, 7], the mechanism of the silhouette transformation of an electronic mannequin is based on graphical operations of the parametric assignment of empirical project body tolerances, which decreases the quality of fitting.

The pattern design systems (PDS) Julivi, Grace (Ukraine), Opti Tex (Israel), Grafis, Novo Cut system (Germany), LEKO, 3D-STAPRIM (Russia) involve the principle of the parametric representation of patterns [8]. For the user, the main focus for the add-on over the empiric designing methodology is aimed at the creative use of heuristic methods of the procedures for a geometric transformation of an object [8, 9].

The use of such principles is justified and effective only if there is an objective system of anthropometric measurements with a high accuracy level and under conditions of application of professional pattern design systems (PDS). When attempting to go beyond these limitations, there arise the objective difficulties associated with uncertainty of the mechanisms of transformation of the frame of a three-dimensional mannequin in the plane of displaying the clothing parts and the transformation of a typical mannequin in an individual project for the figures that are different from typical ones. In papers [1–9], the problem of considering the local processes and phenomena, which describe the algorithm for the interpretation of the theory of assigning object's surfaces in the modification series of garments' surfaces remains unresolved.

A promising option for solving the specified problems is the use of graphical systems that are focused on a complex shape [10, 11]. All leading global companies in the field of development of software garments for the fashion industry contain the modules of visualization of a three-dimensional figure due to a digital image or body-scanning data [12, 13]. Mathematical modeling and the construction of a linear frame is performed with the help of embedded software functions and operators. Software modules of clothing visualization on three-dimensional electronic mannequins propose PDS: Gerber (APDS-3D), PAD Sistem (3D Sample), Julivi (Julivi CLO 3D), Lectra (Modoris 3D Fit), Toyobo (Lookstailor), Optitex (Runway Designer) [8, 14].

An analysis of research into visualization of the human body surface proves the merits of a three-dimensional mannequin, obtained with the help of body-scanning for assigning body measurements with a high level of accuracy, which corresponds to the level of photogrammetry [5, 7]. The program

Julivi CLO 3D contains the mannequins of male, female, and children's figures of the European and Asiatic types. Adjustment of these mannequins to the current applicable national standards of Ukraine makes it possible to obtain a reliable 3D image of the garment for visual fitting.

National anthropometric standards of Great Britain, United States, and Mexico are created based on databases obtained by body scanning, which proves the feasibility of this technology for upgrading anthropometric information [8, 13, 15]. However, the use of a body scanner is costly, and thus inaccessible to most users.

A considerable body of research in the field of 3D design directly address the quality of regarmentation of physical-mechanical properties of fabrics and clothes in the virtual space [15–17]. The authors of papers [9, 10, 13, 14] actively use virtual models of clothes for direct research into designs of women's clothing and assessment of the quality of garments fitting on a figure in terms of convenience and physiological comfort of a consumer. However, the algorithm of ensuring the aesthetic indicators of the clothing fitting quality by the anthropometric correspondence of a consumer's figure was not described procedurally. Adjustment of fitting of a virtual model of clothing is carried out with direct participation of a designer and depends on his intelligence and professional skills.

One of the promising directions of the fashion industry development is the use of Intermeshed network for the varieties of produce distribution. In particular, these are an Intermeshed-studio of bespoke tailoring, an intermeshed site of the own creation of a garment, an intermeshed-project of the own design. The main feature of the specified networks is the remoteness of a consumer from the designing algorithms and the lack of their professional training [3].

The packages of three-dimensional visualization for the use in clothes purchasing through the intermeshed or instead of fitting rooms in the clothing shops are proposed by the companies that do not belong to the developers of fully-fledged CAD. In particular, they are Reflection Fabrix Inc., Digi Scents [4, 18]. At the level of providing individual clothes garmentation in the PDS module Lectra System, the special Fit Meshed program that processes scanned dimensional features is proposed, and special program Modaris Modepro adapts the model of a garment.

However, there are objective reasons associated with the technology of transition from soft shells of clothes on an electronic mannequin to the graphical construction of 2D-patterns. The formulation method for the automatic reconstruction of the original 3D solid object in such common programs as Pro/Engineer, Linigraphics, NX, AutoCAD, Solid Works, Blender Basis is not suited to the technology of scaling soft shells, such as garments. All this makes it possible to assert that the research into the adaptation of heuristic principles of parametric and graphic designing model structures to different PDS of clothes is relevant. Solving these problems will ensure high parametric accuracy of input data and, respectively, the end quality of a project, as well as to propose new algorithms of scenarios of design solutions in the field of 3D design of clothes.

3. The aim and objectives of the study

The aim of our study was to verify the quality of the process of computer designing of garments through the improvement

of the technology of using add-ons of an electronic mannequin in modern PDS.

To accomplish the set aim, the following tasks have been set:

- to substantiate theoretically the original database for frame models of an electronic mannequin;
- to explore the mechanism of the interactive construction of the shells of clothing in the cycle of silhouette deformation;
- to identify the scenarios for practical realization of the modification projects by the optimal route.

4. Materials and methods to study the designing of surfaces of shells of an object

4.1. Computer technologies for the formation of arrays of elements of morphological field of clothes shells

The theoretical prerequisite of modular approaches to the formalization of designing clothing structures as a set of typical parts is the use of the law of mass distribution of the morphological field of a 3D object «Clothes» that is sufficiently represented in studies [6, 19, 20]. Within this study, the authors stated the following principles of actions coordination in the algorithms of conversion of the sets of a research object:

- constructiveness principle: relationship and compliance of a structure with the means of the spatial shape organization;
- ergonomics principle: relationship between a garment and a human, adaptability and ease of a construction, which provides reliability;
- functionality principle: the priority of the basic features of garment’s appearance;
- universality principle: implicative inclusion of typical parameters of form-making elements;
- scaling principle: relationship and correspondence of segmentation of a structural section and valence of a playing field;
- adaptation principle: relationship and compliance of the methods for compression of control (typical) and non-recurrent information in modification;
- diagnosis principle: reliability of the combination of aesthetic and utilitarian properties of the final garment design.

Research [5] proved the feasibility of the application of models of meshed frames for engineering design of three-dimensional geometry. To do this, three types of graphical primitives of 3D designing are used: a point, a line, a face (3D face). These primitives form a group of nine three-dimensional bodies that at the level of software modules are adapted for automated objects’ design.

For example, the mathematical apparatus CSG – Constructive Solid Geometry, which implies a mathematical description of an object and the algebra of mathematical logistics, is applied in AutoCAD for the construction of a digital model of an object.

The technology of combining constituent primitives using a set of special commands ensures the creation of a graphical model of an object by layering separate parts as adjacent transparent sheets, each layer of which has its own name. The layers can be in different states: enabled – disabled; frozen – unfrozen, blocked-unblocked. This makes it possible to simulate the surface of a mannequin as a discrete closed system in the interactive mode. The linear frames of typical divisions with the transformation into flat parts of scanning of clothing are implicatively included into it [21].

In computer graphics, the geometric object of a model is represented by a sequence of three kinds of information

models: digital, meshed, and surface [5]. The models of a cylindrical meshed frame of the mannequin’s surface are shown in Fig. 1.

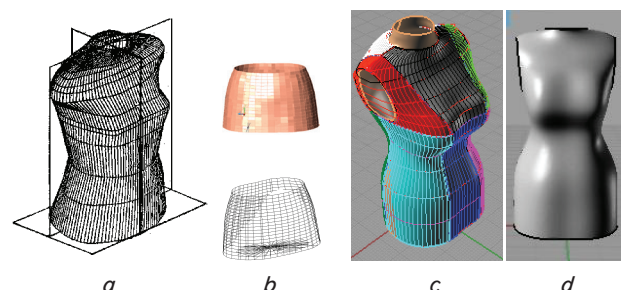

Fig. 1. Graphical 3D models of mannequins of figures: a – meshed; b – meshed-surface; c – meshed-linear; d – surface

Visualization of a meshed frame of the surface of an object is made by cubic splines with the view to creating a surface model of an object for identifying and correcting the form-making elements by using the AVE module (AutoCAD).

The technology of determining the deformations in the cells of a meshed of geodetic parallels implies the application of the color palette for the regarmention of the degree of shell cells tension. The meshed deformation fixes the zones of compression and stretching of the mannequin’s shell relative to the bust line as the original sweep axis.

The algorithm and applied program of anthropometric regulation of an electronic mannequin by the method of proportional transformations of projection body measurements using command 3D MESH (AutoCAD) were proposed.

The apparatus of visual images construction of a digital model of a 3D object makes it possible to take into consideration the topology of the inner geometric structure of a shape. Accordingly, the morphologic field of synergic relations of the elements in the processes of transition from 3D to 2D design for the adaptation of soft shell of clothing to a rigid shell of a mannequin was studied by the mathematical description of interpretation procedures.

4.2. Mathematical interpretation of studying the geometrical models of an object

The features of the human body shape determine the number of geometrical modules in the sweeps of mannequin’s surface $GMsd$. The mathematical model of the group structure of graphic primitives (G) describes the composition of continuous displays q of geometrical modules of the mannequin’s surface $GMsd$ in ϕ of the constructive modules of clothes parts CMC (1):

$$\begin{aligned} \theta \div G \times G &\rightarrow G \text{ } GMsd, \\ \phi \div G \times G &\rightarrow GKM_0. \end{aligned} \tag{1}$$

The automated solution to the problems on creating graphical models of an object both in the form of an electronic mannequin’s and of design documentation requires a corresponding mathematical description of the associations of elementary graphic primitives in the geometric module by constant dimensions. This corresponds to the commands of the image surface in the form of a set of segments of straight

lines for the parameterization of 2D image by the geometric features. The totality of digital models of points G_{ij} – nodes of a meshed frame in the cylindrical coordinate system is accepted as the mathematical model of the surface of a mannequin of a typical figure G (2):

$$MM(G) = \{MM(G_{ij})\}, \quad (2)$$

where each point is characterized by coordinates (3):

$$\cup G_{ij} MM(G_{ij}) = MM(Z_i, R_{ij}, F_j). \quad (3)$$

A digital model of mannequin DMd is a document of an electronic object description and is assigned by a set of horizontal cross sections (I), vertical radial cross half-planes (J).

For a mannequin of a typical female figure 158-88-96 (the basis of a series of sizes of a typical mannequin):

$$I = (1 \div 61), \quad J = 01 \div 23.$$

For a mannequin of a typical male figure 170-92-76 (basic size of the younger age group):

$$I = (1 \div 70), \quad J = 01 \div 36.$$

For the hip area of a typical female figure 158-88-96:

$$I = (1 \div 20), \quad J = 01 \div 23.$$

A step along axis Z is 10 mm, the angle of cylindrical coordinates is 10° .

The observation number for the mathematical model (MM) of the mannequin's surface is determined as the garment of the number of coordinates horizontal cross-sections and the number of vertical cross-sections in the applique of a graphic element. Thus, CMd 158-88-96 contains 1.952 nodal points; CMd 170-92-76 contains 2.520 nodal points; CMd of the hip area contains 460 nodal points.

The graphical model of a linear frame of the mannequin surface in the form of $GMsm$ in the automated systems is provided by the mathematical models of algebraic summing graphic primitives of the coordinates of nodal points. The selection of the linear frame is described by a cubic interpolating spline (4):

$$S(x) = y_1 + b_1(x - x_1) + c_1(x - x_1)^2 + d_1(x - x_1)^3, \quad (4)$$

$$x_1 \leq x \leq x_{i+1}, \quad i = 1, 2, \dots, n.$$

Seven vertical and six horizontal cross sections of a linear frame correspond to typical sectioning of the design of shoulder garments with the fixed design points k_{ij} in the geometric modules of the mannequin surface (5):

$$G \text{ GMsd}_{ij} \subset Gk_{i,j}. \quad (5)$$

The process of deformation of geometrical modules of mannequin surfaces taking into account the structural and technological body tolerances in the digital models of clothes DMC is performed by parametric changes of the coordinates of structural points (6):

$$MM(Gk_0) = \sum_{i=1, j=1}^{1,2} Gk_{i,j} + \sum_{z=1}^Z SA_{Gz} + \sum_{m=1}^M TA_{Gz,i}. \quad (6)$$

The process is the silhouette modification in DMC is performed by a change in the coordinates of a nodal point (7) along the cylindrical coordinate:

$$MM(G_0) = \sum_{i=1, j=1}^{I, J} G_{i,j} + \sum_{z=1}^Z ASi1 + \sum_{m=1}^M \Delta ASi1,2 + \sum_{n=1}^N \Delta ASi2,3, \quad (7)$$

where G_0 is the coordinate of a nodal point of clothes; G_{ij} is the coordinate of a nodal point of the mannequin surface; $ASi1$ is the body tolerance for $Si1$ in a structural point; $\Delta ASi1,2$ is the increment of the coordinate of a structural point between silhouettes $Si1$ and $Si2$; $\Delta ASi2,3$ is the increment of the coordinate of a structural point between silhouettes $Si2$ and $Si3$.

The study of the topography of the areas of linear-changing relations between the surfaces of a mannequin and clothing at the bust line ($Si0 \rightarrow Si1$) (Fig. 2) proved the feasibility of scaling of silhouettes increments $\Delta ASi1,2$, $\Delta ASi2,3$ relative to $ASi1$. The distances between the main structural points (31, 32, 33, 35, 36, 37) determine the parameters of sections of the mannequin and clothes.

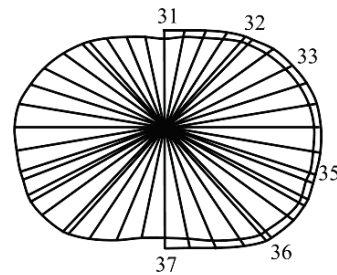

Fig. 2. Topography of the areas of linear-alternating connection of a mannequin surface at the level of projecting bust points

Analytic coordinates of the dart outlines (8) as the segment of vertical segmentation of the shell take into consideration the coincidence of the bend line with axis Oy and the same change of the angles between the warp and weft threads of:

$$X_c = R_c - \sqrt{R_c^2 - y_c^2}, \quad (8)$$

where R_c is the radius of the arc of a circle; y_c is the ordinate of the bend line.

The pitch of plotting arcs is 1.0 cm, which corresponds to the requirements of segmentation by a meshed frame.

The total curvature of axis OY is determined as the sum of the separate sections of concentric arcs (9):

$$R_k = \sum_i^n \Delta y_i, \quad (9)$$

where Δy_i is the curvature of a separate section of the sweep applique.

4.3. Algorithms for the interactive designing of the examined objects

It is possible to represent the spatial shape of sweep parts on a plane by means of its bending by a curvilinear bending line $lbend$ relative to cross section $lcut$. For the convex shape of

the bending line, the mandatory condition is that $lbend > lcut$, which is met by the deformation of the edges compression or the formation of a dart from the cut to remove the excess of a detail on the outline section. For a concave detail, a mandatory condition is that $lbend < lcut$, which is achieved by stretching the edges of parts or by a dart in the middle of a detail.

These conditions characterize the topology of the network of geodesic parallels in the areas of stretching and compression of a garment relative to the lines of busts and the waist.

The weight of internal segmentation in the group of design factors of the fitting quality is 27.9% [5]. It is advisable to use a dart as a non-through kind of segmentation as a design prototype for the performance of modification segmentation.

The algorithm of parametric optimization of a dart prototype is based on the tasks of determining the curvilinearity of outlines by the aperture, length, and the end point of the original dart.

Research into the graphical models of the project field of a bust dart (Fig. 3, a) indicate that a change of the conical shape requires the shaping its sides by the second order curves. The curvature of these lines accordingly depends on the magnitude of the dart reduction and aperture.

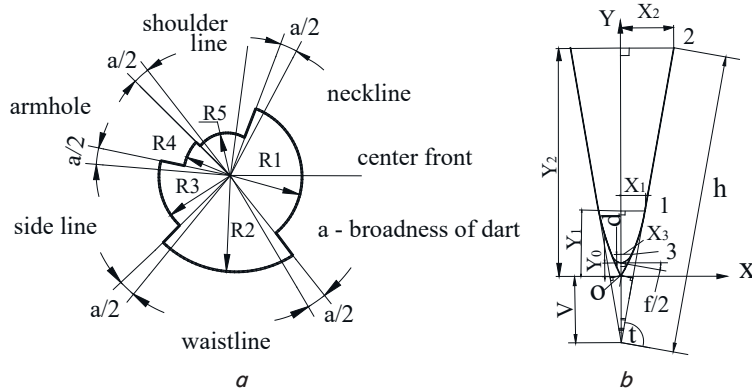

Fig. 3. Graphical model of the project field: a – bust dart in the model position; b – estimated dart scheme; R_1, R_2, R_3, R_4, R_5 are the radii of project field sectors

The mathematical model of the dart line configuration is represented by the system of equations (10):

$$y = \begin{cases} 2\sqrt{ay_0}x, & \text{if } x \in [0, x_3], \\ ax^2 + y_0, & \text{if } x \in (x_3, x_2), \end{cases} \quad (10)$$

where

$$a = \frac{y_2 - y_0}{x_2^2},$$

x_2, x_3, y_2, y_0 are the coordinates of points 0, 2, 3 (Fig. 3, b).

To solve the tasks of the flat-rotating movement of the model darts in the design field sectors, we performed the deconstruction of a dart by the system of concentric circles at the interval of 2 cm, which corresponds to the size interval of indifference (Fig. 4, a) and takes into consideration the dart aperture increments through inter-size changes of the dart length.

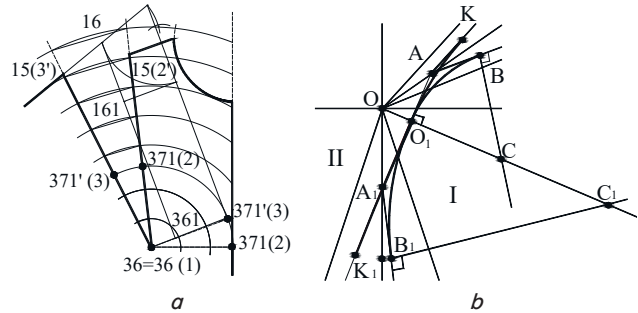

Fig. 4. Flat-rotating movement of a bust dart: a – modification of structural shape-forming elements of the original model design of a front; b – a graphical model of shaping the module of joining bust and waist darts

Joining the outlines of the bust and waist darts forms internal segmentation of a detail by the princess line. The mathematical model of the approximation of the segment of the project field of the junction of curvilinear and straight sections (Fig. 4, b) is represented by the system of equations (11) [22]:

$$b_i = \frac{x_{ki} - x_{01} + d_i y_{ki} - a y_{01}}{d_i - a},$$

$$c_i = a(y_{01} - b_i) + x_{01},$$

$$R_i = \sqrt{(x_{01} - c_i)^2 + (y_{01} - b_i)^2}, \quad (11)$$

where i is the index of the studied arc; R is the radius of the arc of a circle, cm; c, b are the coordinates of the circle arc center, cm; x_{01}, y_{01}, x_b, y_b are the coordinates of the initial and final point of the arc, respectively, cm; a, d are the angular coefficients of straight line AA_1 and the side of the dart, to which the final arc point belongs, respectively.

The research into a range of displacements of internal segmentation of the front relatively to the extreme point of busts by the method of calculation schemes with respect to the harmonious position proved the linear dependence of the range of displacements on the angle of the bust dart slope relative to the bust line (Fig. 5).

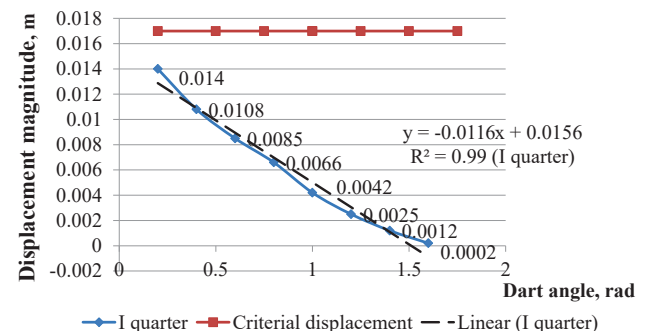

Fig. 5. Dependence of displacements of princess lines, constructed based of a parametric series of harmonic positions of a bust dart

Research into the equilibrium of the shape of designs with the princess lines, calculations of potential energy of deformation of stretching and bending of the elements of fabric

of different density proved an increase in potential energy at an increase in density (Fig. 6).

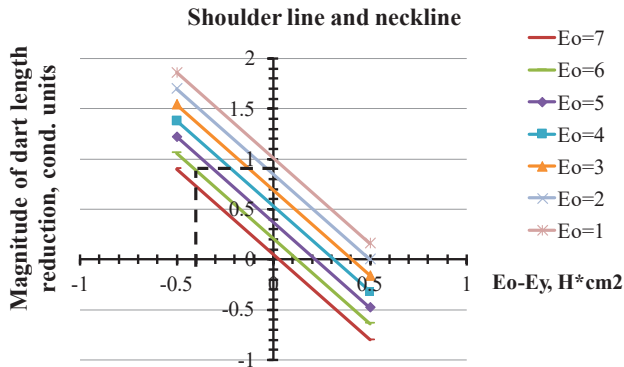

Fig. 6. Finding the dart length reduction by the assigned properties of the material

The passage of the princess line in parts from tight and tough materials through the extreme bust point meets the conditions of the garment balance.

The algorithm of the metrological recognition of research objects was implemented by the mathematical models of synthesis of the elements of group structure of the garment's surface in the segments of an electronic mannequin.

The algorithms of the shape-forming segmentation of the design prototype determine the relationship of silhouette characteristics and curvilinearity of the body coverage areas.

The correction algorithms were implemented by practical recommendations on the optimization of the parameters of the sections of shape formation of the detail design.

5. Results of studying the transformation of digital models of mannequin frames into the projects for modification of design of garment parts

An innovative component of the program to study the surfaces of the object «Clothes» is the adaptation of graphical information to the images structure at the level of design document drawing.

A digital model of the mannequin surface (DM_d) requires significant amount of memory to provide the graphics data of the totality of frame models. Accordingly, the adaptation involves the division of images into non-intersecting segments taking into account the value of their morphological structure.

In the proposed sequence of design transformation of digital models of an object (a meshed frame, a linear frame, a visual model), the algorithm of loss-free compression is used, which makes it possible as a result of decompression to get an image that is identical to the original.

To solve the adaptation problem, the concept of «project field» is used, which determines one or more interest regions in accordance with the scenarios for practical implementation.

Scenario 1 – setting the problems of a typical project of DMd compression. From the mathematical point of view, the region of interest G is a coherent open set in the Euclidean space, assigned by its boundary. Matrix T of dimensionality $m \times n$ will be called the project field of image A , provided $t_{ij} \in \{0,1\}$, where $t_{ij}=1$, if ij coordinate belongs to region G – the set of points of the meshed frame, otherwise $t_{ij}=0$.

An arbitrary image Aa can be considered as an open set, so that:

$$\left\{ a_{ij} \in Aa \begin{cases} 0 \leq a_{ij} \leq L \\ 1 \leq i \leq n \\ 1 \leq j \leq m \end{cases} \right\}, \quad (12)$$

where L is the number of gradations of digital models of an object; m, n assign the dimensions of images of segments of coordinate points of a meshed frame.

Digital image A of dimensions $m \times n$ of the points' coordinates, obtained as a result of the analog-to-digital conversion of the original image A_0 , can be written down in a matrix form:

$$A = \begin{bmatrix} a_{11} & a_{12} & \dots & a_{1m} \\ a_{21} & a_{22} & \dots & a_{2m} \\ \dots & \dots & \dots & \dots \\ a_{n1} & a_{n2} & \dots & a_{nm} \end{bmatrix}, \quad (13)$$

where a_{ij} is the numerical designation of points i, j of the meshed frame.

The methods of construction and compression of project field PF for assigned images A depend on display continuity and on taking into consideration the criteria of influence of the factors of variability of anthropological features stated in [5, 23] on the coordinates of the meshed frame of DM_d . Accordingly, this makes it possible to determine both the magnitude of the sample, and the number of weights to research into body measurements.

Scenario 2 – the method of the silhouette transformation of a digital model of the clothing surface.

The open set of dimensionalities of the silhouette shape with fixed structural points of horizontal cross-sections of structural zones provides the use of the method of affine displacement, employed in scaling sub-programs.

A digital model of the silhouette shape of clothing in the model of a typical project involves the use of standard programs of scaling. In particular, it is described by a matrix of single coordinates of compression by the magnitude of body tolerance:

Direct conversion for Si0-Si1-Si2-Si3:

$$\begin{bmatrix} 1 & 0 & d_x \\ 0 & 1 & d_y \\ 0 & 0 & 1 \end{bmatrix}, \quad (14)$$

the inverse transformation for Si3-Si2-Si1:

$$\begin{bmatrix} 1 & 0 & -d_x \\ 0 & 1 & -d_y \\ 0 & 0 & -1 \end{bmatrix}. \quad (15)$$

Verification of tables of increments $\Delta x, \Delta y$ of the method for silhouette transformation is performed by the solution rules of description of the morphological structure of body tolerances. 2D drawings of silhouette structures form an archive of modification of a typical project.

Scenario 3 – anthropometric modification of an individual project of the garment for a special purpose.

Research [24] showed that the best cosmetic correction of the busts and torso shape by a corset is carried out by tightening the figure by the magnitude of modelling effect, i. e. it is deformation of compression.

An experimental check of modeling effects of eleven body measurements of a special anthropometric program for three conditions of figure tightening proved the effectiveness of modeling effects of the magnitudes of bust girth of the fourth,

the waist girth, the waist cross diameter. The reliability of the anthropometric information was proved by the calculations of statistical parameters: arithmetic mead, median, mode, root mean square deviation, variance, asymmetry, excess, and standard error (Table 1).

Table 1
Results of calculation of modeling effects \bar{d} of body measurements of women in corset

Size feature	Minimum modeling effect				Medium modeling effect				Maximum modeling effect			
	\bar{d} , cm	σ , cm	σ_0 , cm	$\alpha_{0.95}$, cm	\bar{d} , cm	σ , cm	σ_0 , cm	$\alpha_{0.95}$, cm	\bar{d} , cm	σ , cm	σ_0 , cm	$\alpha_{0.95}$, cm
<i>Gb_{III}</i>	-1.3	0.483	0.153	0.346	-2.4	0.459	0.145	0.329	-3.2	0.632	0.200	0.452
<i>Gb_{IV}</i>	-1.4	1.88	0.6	1.35	-1.45	1.23	0.39	0.88	-2.95	1.98	0.63	1.42
<i>Gw</i>	-2.2	0.42	0.13	0.3	-4.2	0.48	0.15	0.35	-6.9	0.74	0.23	0.53
<i>db_{III}</i>	-0.35	1.00	0.32	0.72	-0.4	1.1	0.35	0.79	-0.35	1.29	0.41	0.92
<i>db_{IV}</i>	-0.45	0.64	0.2	0.46	-1.05	0.64	0.2	0.46	-1.75	0.42	0.13	0.3
<i>dw</i>	-2	1.179	0.373	0.843	-3.15	1.435	0.454	1.026	-4.35	1.547	0.489	1.106
<i>dh</i>	-0.5	1.18	0.37	0.84	-0.7	0.48	0.15	0.35	-1.1	1.13	0.36	0.81
<i>dsvb_{III}</i>	-0.95	0.69	0.22	0.49	-1.35	0.71	0.22	0.51	-1.75	0.92	0.29	0.66
<i>dsvb_{IV}</i>	0.2	0.26	0.08	0.18	0.35	0.58	0.18	0.41	0.65	0.78	0.25	0.56
<i>dsvw</i>	-0.1	0.699	0.221	0.5	-0.05	0.956	0.302	0.684	0.15	1.375	0.435	0.984
<i>dsvh</i>	-0.05	1.23	0.39	0.88	-0.35	1.33	0.42	0.95	-0.75	2.12	0.67	1.52

Table 1

Table 2
Results of calculation of quantiles of modeling effects of body measurements of women in corset

Size feature	Modeling effect					
	Minimum		Medium		Maximum	
	$d_{0.95}$	$d_{0.50}$	$d_{0.95}$	$d_{0.50}$	$d_{0.95}$	$d_{0.50}$
<i>Gb_{III}</i>	-0.74	-1.3	-1.82	-2.38	-2.27	-3.21
<i>Gb_{IV}</i>	1.66	-1.38	-1.32	-1.41	0.25	-2.95
<i>Gw</i>	-1.54	-2.19	-3.51	-4.22	-5.66	-6.93
<i>db_{III}</i>	0.17	-0.36	0.26	-0.41	0.45	-0.35
<i>db_{IV}</i>	0.35	-0.47	0.36	-1.08	-1.14	-1.78
<i>dw</i>	-0.44	-2.02	-1.1	-3.15	-2.03	-4.36
<i>dh</i>	1.03	-0.5	0.07	-0.7	-0.23	-1.1
<i>dsvb_{III}</i>	-0.09	-0.95	-0.52	-1.35	-0.54	-1.75
<i>dsvb_{IV}</i>	0.62	0.2	1.28	0.35	1.86	0.65
<i>dsvw</i>	0.98	-0.11	1.45	-0.05	2.31	0.15
<i>dsvh</i>	1.02	-0.05	0.44	-0.35	0.34	-0.75

The compression of a frame model of a typical mannequin was performed in the automated mode (Fig. 9).

The results of correlation analysis revealed that there is a close relation ($r_{xy}=0.982$), between the tightened waist girth (Gw_t) and fourth bust girth (Gb_{IV}), which made it possible to perform regression analysis of a change of parameters ΔGw , Gw , Gb_{IV} , as a result of which we obtained the equation for determining the maximum modeling effect of the torso of the female figure on the waist line:

$$y = 77.44 - 1.51 \cdot x_1 + 0.64 \cdot x_2, \tag{16}$$

where y is the magnitude of maximum figure tightening on the waist line; x_1 in the fourth bust girth; x_2 – waist girth.

Fig. 7 shows the diagrams of changing the maximum magnitude of modeling effect of typical figures of fullness I–IV.

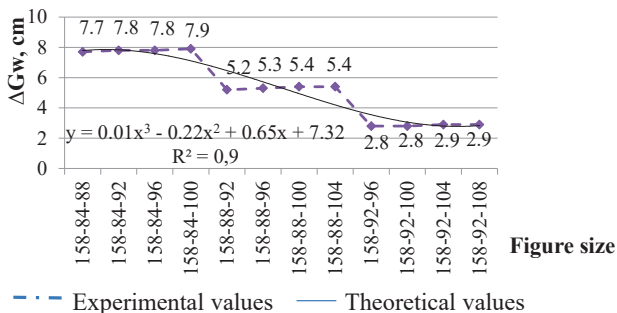

Fig. 7. Diagram of changing maximum magnitude of modeling effect of typical figures of fullness I–IV

Reliability of the overall modeling effect was checked by calculations of quantiles of modeling effects of body measurements based on using linear regression function (Table 2).

Fig. 8 shows dependences of quantiles of minimum (dI), medium (dII) and maximum of tightening (dIII) on values of girth body measurements.

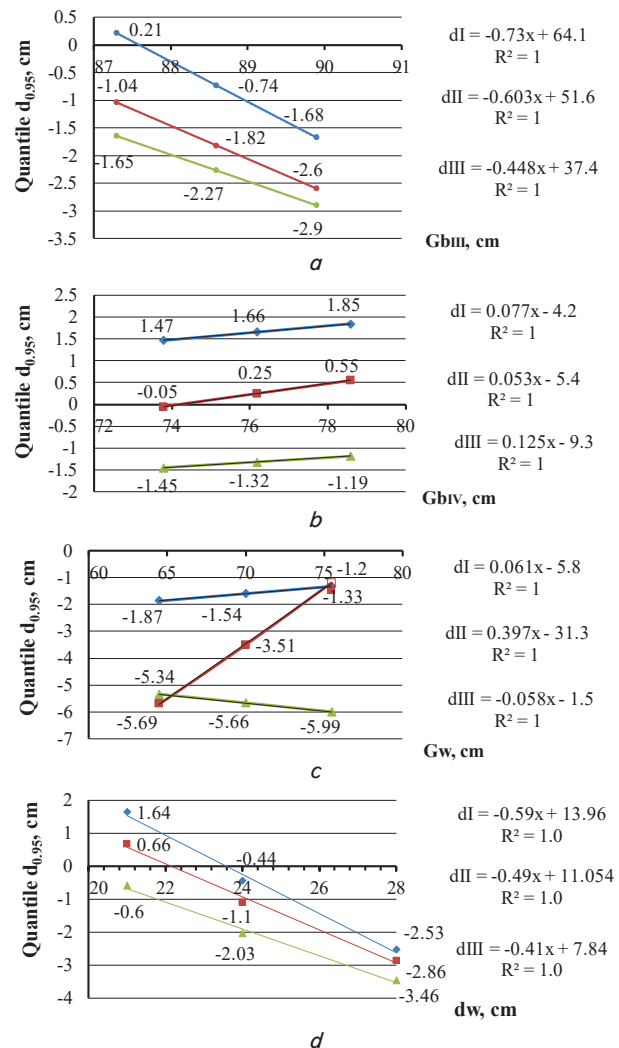

Fig. 8. Dependence of quantiles dI, dII, dIII on value of body measurements: a – Gb_{III} ; b – Gb_{IV} ; c – Gw ; d – dw

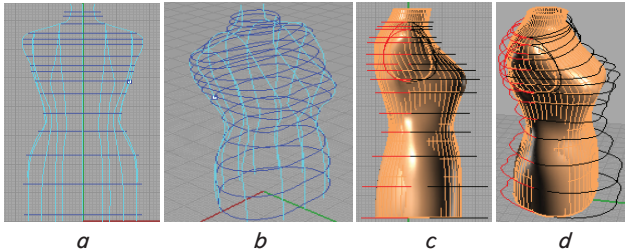

Fig. 9. Generation between horizontal cross-sections of the mannequin surface: *a* – a typical mannequin without tightening (front view); *b* – a typical mannequin without tightening (side view); *c* – tightened mannequin (side view); *d* – tightened mannequin (side view)

The values of transverse diameters of the figure at maximum modeling effect decrease on average on the line of the third busts girth by 0.35 cm, of the fourth busts girth – by 1.75 cm, of waist – by 4.35 cm, of hips – by 1.1 cm. Anterior-posterior diameters decrease on the line of the third busts girth by 1.75 cm and increase on the line of the fourth busts girth by 0.65 cm, of waist – by 0.15 cm, of hips – by 1.6 cm.

The critical parameters of figure correction by a corset were established based on the diagnosis of consumers' feelings (Table 3).

Table 3

Variative table for determining the critical correction parameters for typical figures 88–96 and fullness of groups I and II

Size of a typical figure	Critical magnitudes of simulation effect, cm								
	I fullness								
	minimum			medium			maximum		
	Gb_{III}	Gb_{IV}	Gw	Gb_{III}	Gb_{IV}	Gw	Gb_{III}	Gb_{IV}	Gw
84	–	–1.7	–2.6	–0.5	–1.8	–6.4	–1.0	–3.4	–7.2
88	–2.0	–1.4	–2.4	–2.5	–1.5	–4.7	–3.0	–3.0	–5.5
92	–3.0	–1.1	–2.2	–4.5	–1.2	–3.0	–5.0	–2.6	–3.8
96	–5.0	–0.8	–2.0	–6.5	–0.9	–1.3	–7.0	–2.2	–2.1
Size of a typical figure	II fullness								
	minimum			medium			maximum		
	Gb_{III}	Gb_{IV}	Gw	Gb_{III}	Gb_{IV}	Gw	Gb_{III}	Gb_{IV}	Gw
	84	–	–1.6	–2.5	–0.5	–1.7	–5.8	–1.0	–3.5
88	–2.0	–1.3	–2.3	–2.5	–1.4	–6.0	–3.0	–3.0	–6.8
92	–3.0	–1.0	–1.8	–4.5	–1.1	–6.2	–5.0	–2.7	–7.0
96	–5.0	–0.7	–1.6	–6.5	–0.8	–6.4	–7.0	–2.4	–7.2

The magnitudes of negative body tolerance s in the structures were differentiated for three silhouettes that correspond to minimum $Si1$, medium $Si02$ and maximum $Si01$ modeling effects on three structural areas (Table 4).

The recommendations were developed on the application of compromise magnitudes of broadness of waist darts $\Delta_{tb}=0.35\Delta t$ (back); $\Delta_{tf}=0.29\Delta t$ (front); $\Delta_{ts}=0.36\Delta t$ (side) for taking into account the outlines of back, front and side of three types of figures.

Table 4

Rational negative design body tolerances for free fitting for a corset

Silhouette name	Silhouette designation	Body tolerance by line Gb_{III}	Body tolerance by line Gb_{IV}	Body tolerance by line Gw
		$ACGb_{III}$, cm	$ACGb_{IV}$, cm	$ACGw$, cm
Tight fit	$Si01$	–3.0	–3.0	–6.0
Fit	$Si02$	–2.5	–1.4	–4.0
Half-fit	$Si1$	–2.0	–1.3	–2.0

Scenario 4 – structural modification of the experimental project of the universal design of waist garments.

The universal design implies expansion of functional properties through a combination of design types based on the replacement of structural zones of shape forming elements by the aggregation method (Fig. 10).

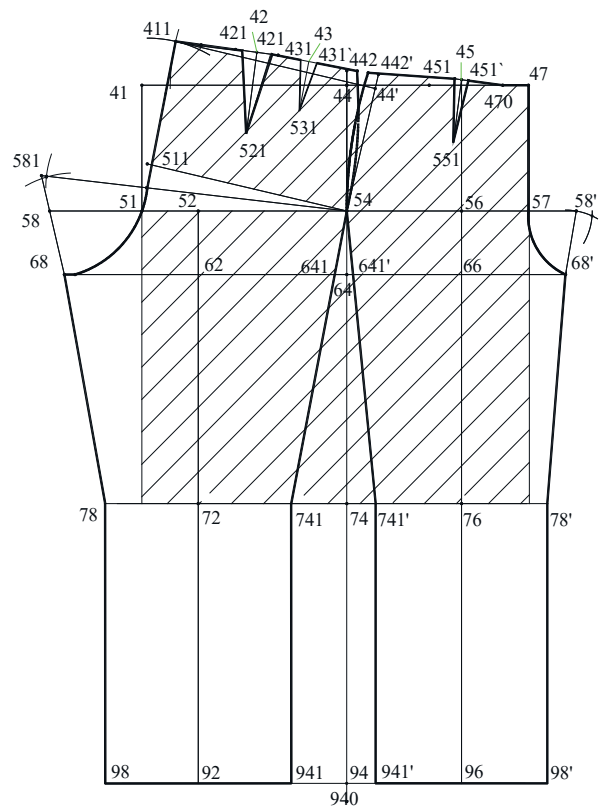

Fig. 10. Pattern of the universal design of waist garments

Options of the development of the scheme of interactive design of a straight skirt as a geometric prototype of a design of classic trousers are based on the method of heterogeneous scaling of the parameters of nodal (basic) design points of outlines of parts (Fig. 11).

Blocks of transformations of the skirt sections into the trousers sections are subordinated to body sections by the surface of covering. The algorithm of project procedures of high-speed design by scenario 1 implies the transformation of the hip and lower sections of a skirt into similar sections of trousers. The transformation of the hip section is carried out by means of the following transformations: determining the

outlines of the hip section of a skirt; transferring the hip section of a skirt into the hip section of trousers (Fig. 12, *a, b*); performance of tough turning of the back hip section of trousers (Fig. 12, *c*). The transformation of the lower section is performed by affine transformation of the lower part of a skirt into the middle section of the trousers (Fig. 13, *a*);

modification of the lower area of the trousers and its joining to the middle section (Fig. 13, *b*).

Research into variability of the magnitude of balance during a tough turn proved the influence on the sizes of a silhouette body tolerance on magnitudes of increments $\Delta x, \Delta y$ (Table 5).

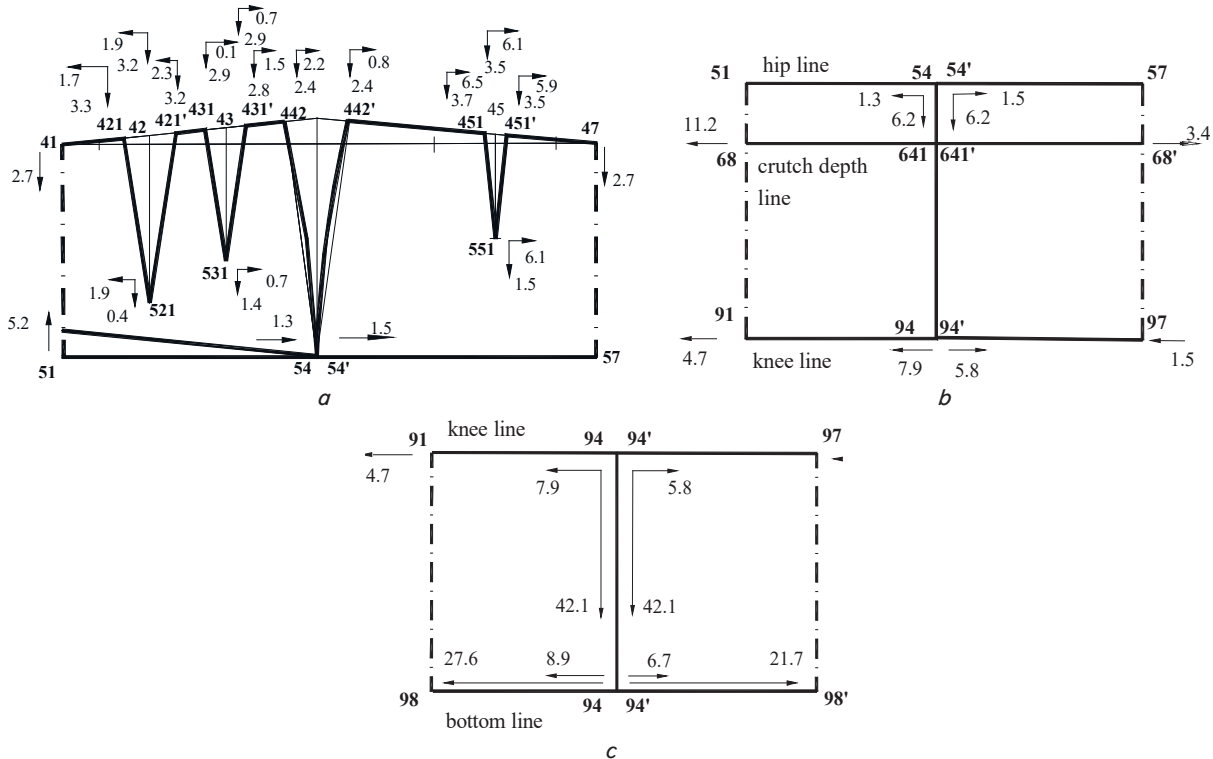

Fig. 11. The pattern of parametric transformation of the modules of interactive design of a women's skirt into the design of women's trousers for size 158-88-96: *a* – hip section; *b* – middle section; *c* – lower section

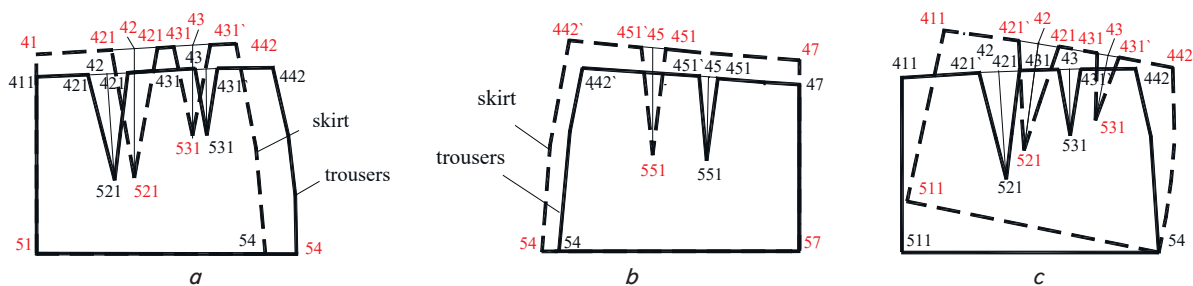

Fig. 12. Patterns of transformation of the hip section of a skirt into the hip section of trousers: *a* – back; *b* – front; *c* – scheme of tough turn of the back hip section of trousers

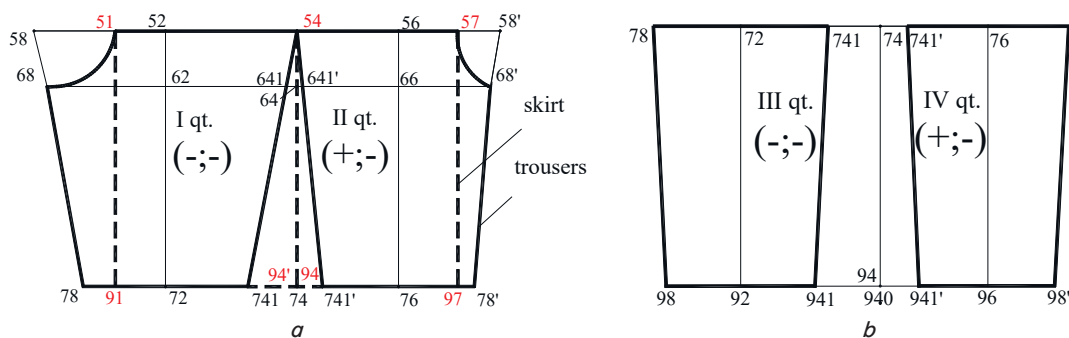

Fig. 13. Patterns of affine transformation of design of a skirt into the design of: *a* – medium section of trousers; *b* – lower section of trousers

Table 5

The magnitude of a turn of the back hip section at the change of body tolerance to the girth of hips and knees for the sizes of group 1 (fragment)

Magnitudes of body tolerance s		Magnitude of angle of a turn /51-511/, cm					
Gh, cm	Gk, cm	158-84-92	158-88-96	158-92-100	158-96-104	158-100-108	158-104-112
0.0	0	5.71	6.34	6.95	7.63	8.32	9.04
	3.0	5.17	5.78	6.37	6.99	7.7	8.4
	6.0	4.63	5.23	5.79	6.39	7.08	7.75
0.5	0	5.96	6.61	7.19	7.93	8.62	9.35
	3.0	5.42	6.05	6.6	7.28	8.0	8.7
	6.0	4.88	5.48	6.02	6.68	7.37	8.06
1.0	0	6.23	6.89	7.52	8.2	8.93	9.67
	3.0	5.68	6.32	6.93	7.54	8.3	9.02
	6.0	5.13	5.75	6.34	6.94	7.67	8.37
2.0	0	6.76	7.4	8.1	8.82	9.56	10.31
	3.0	6.2	6.82	7.5	8.15	8.92	9.66
	6.0	5.65	6.23	6.9	7.53	8.28	8.98

A linear variability of magnitudes of increments in the middle and lower sections of the front and back parts of the skirt and the trousers was detected.

Based on the results of research into the range of body tolerance s along the waist lines (1.0–2.0 cm), hips (0.0–4.0 cm), the differentiated basic silhouette body tolerances *ASi1*, *ASi2*, *ASi3* were determined, which provides the silhouette transformation of the universal design by scenario 2.

Based on the calculation of the indicators of proportionality indices, the feasibility of the morphological modification of the hip section on waist darts scaling taking into consideration the types of projections of buttocks, abdomen and thighs was proved (Fig. 14).

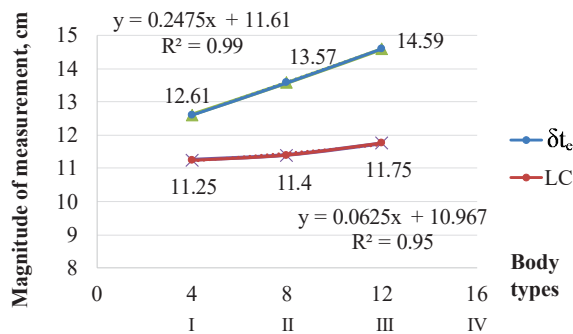

Fig. 14. Dependence of the estimated broadness of darts on fullness number and lateral curvature at the level of the waist line by the projection method

The developed sub-program «Universal structure» supports the data conversion from the software environment «Grace», Julivi, AutoCAD, oriented to the gaming spaces of the structural zones of typical segmentations, runs in the passive dialog mode.

6. Discussion of results of practical application of design scenarios for interactive modification of garment parts

In determining the effectiveness of project transformations of digital models of an object (a meshed frame, a linear frame, a visual model), which follows from the obtained graphic models (Fig. 1), the application of the logical principles of coordination of actions for the selection of the modification algorithm is reasonable. It should be noted that the selection of the means of spatial organization of a shape based on the linear-variable connection in topological transformations does not explain the mechanism of the interpretation of the areas of compression and stretching of mannequin's shells.

In this sense, it is advisable to engage the loss-free algorithm of the mannequin's frame compression, which makes it possible to obtain the image that is identical to the original one due to recompression.

To prove this statement, the algorithm of metrological recognition of the elements of group structure of the garment surface was proposed.

The description of the shape forming segmentation by scenario 1 opens the possibility to take into account the silhouette characteristic and curvilinearity of the areas covered by clothes with the use of affine displacement in scaling sub-programs.

This is in line with the practical data, known from works [5, 9], which correspond to the methods of compression of a set of horizontal cross-sections by scenario 2. The obtained data on the influence of silhouette body tolerances and a structural decision on the process of interactive design, in contrast to the research results published in [6, 9], make it possible to state the following:

- the main regulator of the selection of a modification scenario is not so much the complexity of the morphological structure of the design object as the type of project in the processes of transition from 3D to 2D design;

– a significant effect on synergistic relations of the elements of the morphological is made by the verification of the database of 2D design documents involved in the interactive design technology.

Such conclusions may be considered appropriate from the practical point of view because they provide a reasonable approach to determining the garment comfort.

By the modification of the matrix design of a garment by the method of its silhouette transformation by scenario 3, it is possible to obtain high-comfort garments at the minimum and medium figure tightening, which is proved by the assessment of the static correspondence of a corset – 4.77 points.

The term of the construction of silhouette designs is reduced by 26 % by the generation of information database in CAD «Grazia».

From the theoretical point of view, using the combinatorics of increments, derived by the graphic-analytical method [25], by changing the values of body measurements and body tolerance s for free fitting by scenario, it is possible to obtain the silhouette drawings that do not need checking in the layout.

Thus, the comprehensive ergonomic indicator of the static compliance of a sample of trousers $P_{ct}=4.84$ points proves a high level of quality.

The research results were implemented at LLC «Polonne Trousers Factory», Khmelnytska Oblast, Ukraine.

The unified type of modification scenarios implies an opportunity to obtain the solution of the object project field by means of parametric scaling of the separate elements of the original design.

However, we cannot but note that the results of the morphological modifications of the structural zones depend on the fullness number and indicate the ambiguous impact of indicators of proportionality index on scaling the shape-forming segmentations. This uncertainty imposes some restrictions on the use of the passive dialog mode in the construction of the interactive design that could be considered as a disadvantage of this study. The inability to remove the named limitations within the framework of this study generates a potentially interesting direction for further

research. They, in particular, can be focused on the detection of game spaces of the transformation of structural zones of typical segmentation. Such detection will make it possible to explore the transformational conversions of modification vectors and to identify the input variables of design procedures that significantly influence the ergonomic indicator of the static correspondence.

7. Conclusions

1. The conducted research theoretically and experimentally substantiated the source database of the structural elements of frame models of mannequins with the mathematical interpretation of the description of increments of the coordinates of design points in scenarios of add-ons of an electronic mannequin.

2. We developed the algorithms for interactive designing that contain mathematical substantiation of the options for modifying an electronic mannequin taking into consideration the add-on of synergic relationships of the shape and the design of a garment in operations of modification of internal segmentations using the parametric optimization of the dart prototype.

3. Based on the method of displaying the group structures of the «project field» of modification, we developed the scenarios for the interaction of design stages, such as «a typical project», «an individual project», «a special project» in the adaptation of the 3D image of the garment to 2D images of design documents according to the stated rules of formalization of silhouette body tolerance s and the options of design points scaling.

Acknowledgements

We express our gratitude to Yulia Volodymyrivna Vovk, Cand. of Tech. Sciences, KNU, for participation in the study, presented in chapter 5 (scenario 4), Anna Volodymyrivna Selezniova, Cand. of Tech. Sciences, KNU, scenario 3.

References

1. Voroncova E. A., Danilova O. N., Slesarchuk I. A. Kombinirovanny metod sozdaniya razlichnyh form odezhdy na osnove 3D proektirovaniya // Fundamental'nye issledovaniya. 2015. Issue 7. P. 111–115.
2. The role of mass customisation in the apparel industry / Nayak R., Padhye R., Wang L., Chatterjee K., Gupta S. // International Journal of Fashion Design, Technology and Education. 2015. Vol. 8, Issue 2. P. 162–172. doi: <https://doi.org/10.1080/17543266.2015.1045041>
3. Porterfield A., Lamar T. A. M. Examining the effectiveness of virtual fitting with 3D garment simulation // International Journal of Fashion Design, Technology and Education. 2016. Vol. 10, Issue 3. P. 320–330. doi: <https://doi.org/10.1080/17543266.2016.1250290>
4. Sayem A. S. M., Kennon R., Clarke N. 3D CAD systems for the clothing industry // International Journal of Fashion Design, Technology and Education. 2010. Vol. 3, Issue 2. P. 45–53. doi: <https://doi.org/10.1080/17543261003689888>
5. Slavinska A. L. Metody i zasoby antropometrychnykh doslidzhen dlia proektuvannia odiahu: monohrafiya. Khmelnytskyi: KhNU, 2012. 191 p.
6. Razdomahin N. N., Basuev A. G., Surzhenko E. Ya. Sistema trekhmernogo avtomatizirovannogo proektirovaniya v industrii mody // Moda i dizayn: istoricheskiy opyt – novye tekhnologii: Mezhdunarodnaya konferenciya, SPgGUTD. Sankt-Petrburg, 2012. P. 91–92.
7. Computerized pattern making focus on fitting to 3D human body shapes / Sook Cho Y., Tsuchiya K., Takatera M., Inui S., Park H., Shimizu Y. // International Journal of Clothing Science and Technology. 2010. Vol. 22, Issue 1. P. 16–24. doi: <https://doi.org/10.1108/09556221011008776>

8. Pashkevych K. L. Vybraiemo SAPR dlia shveinoho vyrobnytstva // *Lehka promyslovist*. 2012. Issue 4. P. 47–48.
9. Lo Yu., Kuz'michev V. E. Tekhnologiya parametrizatsii formy odezhdy // *Shveynaya promyshlennost'*. 2010. Issue 2. P. 31–33.
10. Aileni R. M., Farima D., Ciocoiu M. Simulating cloth in realistic way using vertices model based // 7th International Conference – TEXSCI 2010. Liberec, 2010. doi: <https://doi.org/10.13140/rg.2.1.2518.3440>
11. Liu Y.-J., Zhang D.-L., Yuen M. M.-F. A survey on CAD methods in 3D garment design // *Computers in Industry*. 2010. Vol. 61, Issue 6. P. 576–593. doi: <https://doi.org/10.1016/j.compind.2010.03.007>
12. Krzywinski S., Siegmund J. 3D Garment Development for Loose-Fitting Garments Based on Parametric Human Models // *IOP Conference Series: Materials Science and Engineering*. 2017. Vol. 254. P. 152006. doi: <https://doi.org/10.1088/1757-899x/254/15/152006>
13. Usability of 3D anthropometrical data in CAD/CAM patterns / Dāboliņa I., Viļumsone A., Dāboliņš J., Strazdiene E., Lapkovska E. // *International Journal of Fashion Design, Technology and Education*. 2017. Vol. 11, Issue 1. P. 41–52. doi: <https://doi.org/10.1080/17543266.2017.1298848>
14. Andreeva E. G., Petrosova I. A., Boyarov M. S. Proektirovanie vneshney formy muzhskoy odezhdy na osnove trekhmernogo skanirovaniya // *Shveynaya promyshlennost'*. 2013. Issue 2. P. 33–34.
15. Baranova T. M. Avtomatyzatsiya protsesu formuvannia antropometrychnoi bazy danykh dlia rozrobky konstruktsiy v umovakh masovoho vyrobnytstva // *Problemy legkoy i tekstil'noy promyshlennosti Ukrainy*. 2010. Issue 1. P. 5–8.
16. Guo M., Kuzmichev V. E., Adolphe D. C. Human-Friendly Design of Virtual System «female Body-dress» // *Autex Research Journal*. 2015. Vol. 15, Issue 1. P. 19–29. doi: <https://doi.org/10.2478/aut-2014-0033>
17. Mengna G., Kuzmichev V. E. Pressure and comfort perception in the system «female body-dress» // *Autex Research Journal*. 2013. Vol. 13, Issue 3. P. 71–78. doi: <https://doi.org/10.2478/v10304-012-0032-6>
18. Murahovskaya-Pechenezhskaya E. Yu., Ryabchikov N. L. Estimation of accuracy of the dimensional characteristics of complex objects with kinect systems // *ScienceRise*. 2015. Vol. 3, Issue 2 (8). P. 86–91. doi: <https://doi.org/10.15587/2313-8416.2015.39363>
19. Kuleshova S. G. Preconditions using of fractal art for structural analysis of the fashionable costume // *Visnyk Khmelnytskoho natsionalnoho universytetu*. 2015. Issue 2 (223). P. 55–61.
20. Mokeeva N. S., Yurina Yu. V. Osobennosti proektirovaniya novyh modeley odezhdy iz unificirovannykh elementov // *Shveynaya promyshlennost'*. 2012. Issue 1. P. 40–42.
21. Zakharkevich O. V., Kuleshova S. G. Development of the method of scaling patterns and virtual garments forms // *Vlakna a Textil*. 2017. Issue 4. P. 34–40.
22. Ihnatyshyn M. I., Matviychuk S. S. Osoblyvosti aproksymatsiyi konturu detalei odiahu polinomamy ta liniyamy druhoho poriadku // *Visnyk Khmelnytskoho natsionalnoho universytetu*. 2012. Issue 5. P. 72–78.
23. Syrotenko O. P., Slavinska A. L. Doslidzhennia zakonmirstei zminiuvannia proektsiynykh vymiriv tuluba zhinochykh fihur // *Visnyk Khmelnytskoho natsionalnoho universytetu*. 2009. Issue 2. P. 198–201.
24. Selezneva A. V., Slavinskaya A. L. Opredelenie modeliruyuyushchego efekta zhenskoy figury, sozdavaemogo korsetom, s uchetom psihofiziologicheskogo komforta // *Izvestiya vysshih uchebnykh zavedeniy. Tekhnologiya tekstil'noy promyshlennosti*. 2014. Issue 2 (350). P. 102–106.
25. Slavinska A. L., Vovk Yu. V. Sposib peretvorennia konstruktsiy zhinochoi spidnytsi v konstruktsiyu shtaniv: Pat. No. 53834 UA / zaiavnyk i patentovlasnyk Khmelnytskyi natsionalnyi universytet. No. u201002322; declared: 01.03.2010; published: 25.10.2010, Bul. No. 20.