

У даній роботі викладено результати проведеного аналізу у Flow Simulation впливу негерметичності камери згорання на ККД твердопаливного котла. Запропоновано конструкцію механізму запирання та розраховано силове навантаження на основні деталі.

Ключові слова: твердопаливний котел; solidworks simulation; метод скінчених елементів; віртуальні та емпіричні дослідження.

A.V. SVINTSITSKIY, V.P. TKACHUK, K.S. SOKOLAN  
Khmelnyskiy National University

### IMPROVEMENT OF CLOSING MECHANISM CONSTRUCTION OF SOLID-FUEL BOILER WITH THE OBJECT OF INCREASING ITS ECONOMY

The most wide spreaded mechanisms of closing solid-fuel boilers are analyzed in this article and there deficiencies and advantages are detected. The calculation of volumes and masses of combustion products and waste gases was realized. Simplified 3-D model of solid-fuel boiler was created. The analysis in Flow Simulation of the influence of thin heat-insulated cord Izopac 57 to the window of the boiler on the efficiency factor was carried out. Simulation of solid-fuel boiler operation was carried out under normal conditions, with value of natural draught with depression in flue 15 Pa. After analyzing problems that occur during production and exploitation of solid-fuel boilers and after processing received experimental results it was determined that rotational mechanism must have possibility of adjusting pressing force of locking screen to the bode, and have possibility to adjust inclination angle of the screen relatively to the horizontal surface of the boiler's window in closed position. This adjusting will provide firm adherence to heat insulating cord and solve problem with jamming. On the basis of construction analysis of existing closing mechanisms the construction, which provides stable hermetic closing of the boiler due to compliant display and possibility of adjusting relatively to the window in three dimensions was offered. The calculation of the most vulnerable elements of construction was carried out in SolidWorks Simulation. The calculation of the hook's handle form that contacts with ear was carried out and examination for a possibility to self-dependent opening was performed. The force, which must be applied to the handle for closing boiler and for providing its hermeticity was calculated. 3-D model of closing mechanism construction was developed and created. The technology of production hook detail was developed. Using CAMWorks software the program of part processing on the lathe HAAS VFI was created.

Keywords: solid-fuel boiler; solidworks simulation; finite element method; virtual and empiric researches.

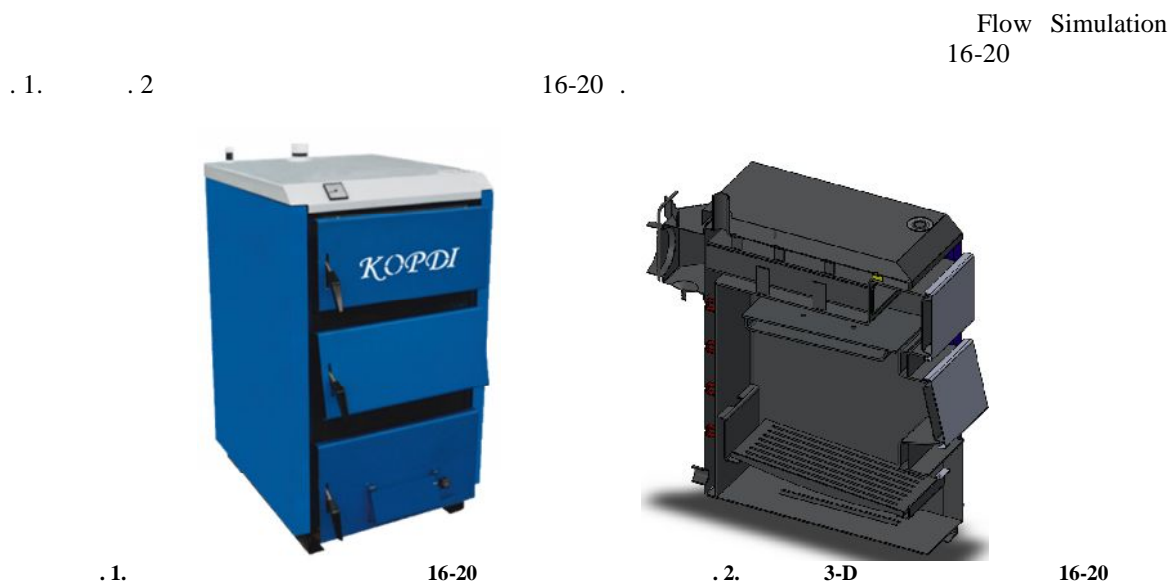

0,1, 0,5 1 .  
 . 3.  
 =0,1 . =0,5  
 ( .  
 =1 . . 4  
 ).  
 0,3%. 0,7%. 0,9%.  
 , 20% 30 3/ .  
 : 0,1 -0,09 3, 0,5 -0,21  
 3 1 -0,27 3.

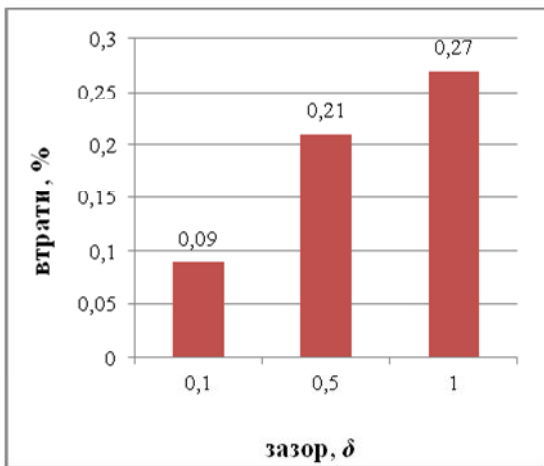

.3.

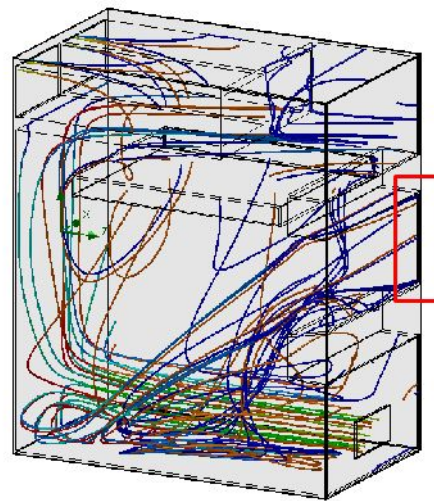

.4.

$$C^p = 52.1\%; H^p = 3.8\%; S^p_4 = 2.9\%; N^p = 1.1\%; O^p = 9.1\% .$$

$$V_{RO_2} = \frac{M_{CO_2}}{\rho_{CO_2}^H} + \frac{M_{SO_2}}{\rho_{SO_2}^H} = 1,866 \frac{52.1 + 0,375 \cdot 29}{100} = 0,99 \text{ }^3/ . \quad (1)$$

$$V_{N_2} = \left( \frac{V_B^O}{100} \cdot 79 \right) + \frac{N^p}{100 \rho_{N_2}} = 0,79 \cdot 5,03 + 0,8 \frac{1,1}{100} = 3,98 \text{ }^3/ . \quad (2)$$

$$V_{H_2O}^O = (0,111 \cdot H^p) + 0,0124W^p + 0,0161V_B^O + 1,24W = 0,111 \cdot 3,8 + 0,0124 \cdot 9,1 + 0,161 \cdot 5,03 = 0,62 \text{ }^3/ . \quad (3)$$

$$V = V_{H_2O}^O + V_{RO_2} + V_{N_2} + V_B^O (\alpha - 1) = 0,99 + 3,98 + 0,62 = 5,59 \text{ }^3/ . \quad (4)$$

$$\alpha = 1$$

5,59 3

[2, 3].



CO  $q_3$

1

		1	2	3
	$\alpha_2, \%$	4,7	4,9	5,4
	$q_2$	214	18	30
	$\alpha_2, \%$	4,8	5	5,5
	$q_2$	202	40	57
		1,26	1,27	1,31
		1,27	1,28	1,32
	$\alpha, \%$	6,34	6,45	6,7

$\alpha$   $q_2$

$\alpha$

$q_2$

2.

$q_2$

?

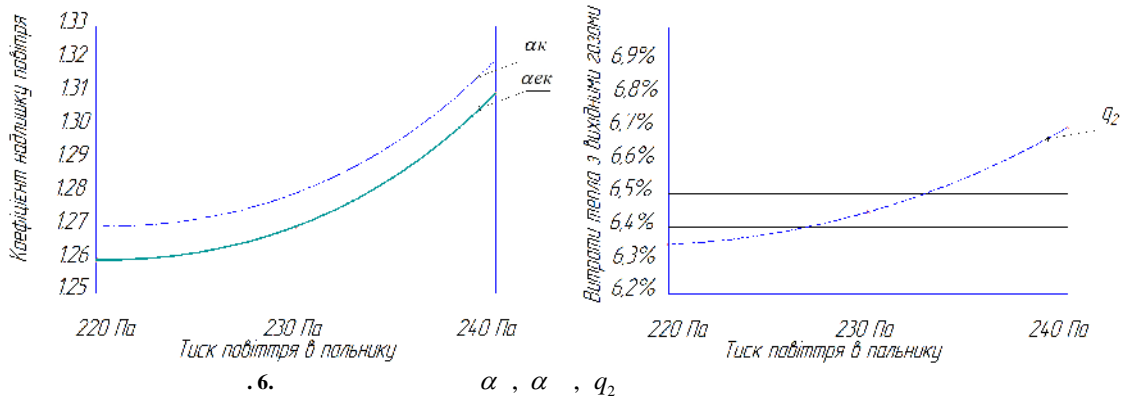

2

	158,7	152
..	1,34	1,28
..	7,02	6,41

0,1

4-5%.

$\Delta\alpha = 0,1-0,2$

4-8°

2

$q_2$

-4-13

77%

$$q_2 : \Delta q = \left( \frac{\alpha_1 - \alpha_2}{\alpha_1} \right) + \left( \frac{t_1 - t_2}{t_1} \right) \cdot q_2 \quad (8)$$

$\alpha_1$  – ;  
 $\alpha_2$  – ;  
 $t_1$  – . . . ;  
 $t_2$  – . . . .

$$\Delta q = \left( \frac{1.34 - 1.28}{1.34} \right) + \left( \frac{158.7 - 152}{158.7} \right) 7.02 = 0.61\% \quad (9)$$

0,61%.

( . 7).

21-

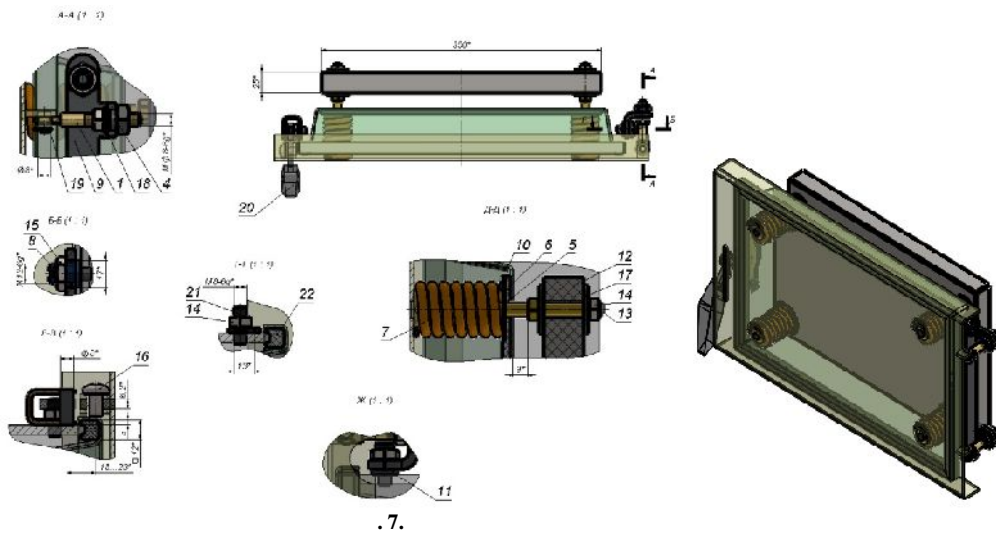

( . 2).  
 12, 13, 14, 17.  
 ( . 10).  
 ( . 10)  
 ( . 5)  
 ( . 13) « » ( . 2).  
 ( . 12) Ø10 ( . 17)  
 ( . 17) 8 ( . 14).  
 ( . 7) ( . 5) ( . 2). ( . 13)  
 ( . 9) 8,  
 8). ( . 11) ( . 9).  
 ( . 14) . 15). ( . 9) ( . 9).  
 4), ( . 1) ( . 14). ( . 14). ( . 14).  
 ( . 1). ( . 1). ( . 19)  
 ( . 16). ( . 20)  
 ( . 22), ( . 5)  
 ( . 7)  
 ( . 5)

( .8) ( .14) ( .4) ( .1).

IZOPAK-57 12 12 .

IZOPAK-57 0,3...0,4 .

IZOPAK-57  
 250 390 , 6 . ( ²):  

$$S_k = 2((l + 2t)t + h \cdot t) = 2((390 + 2 \cdot 6)6 + 250 \cdot 6) = 7824 \quad (10)$$

1.8 25%  
 1 2,3  
 1 2 3  
 2 3 .

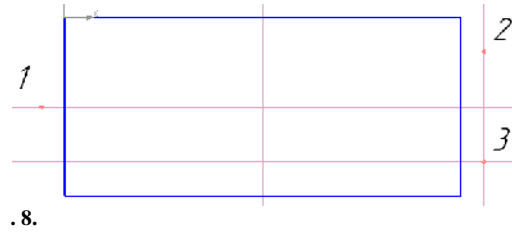

$$P_1 = P_2 + P_3; \quad P_2 = P_3. \quad (11)$$

$$P = S \cdot P ; \quad P = 7824 \cdot 0,4; \quad P \approx 3130 . \quad (12)$$

$$P_p = P \cdot 1,25 = 3130 \cdot 1,25 = 3912H. \quad (12)$$

$$P_1 = P_p / 2 = \frac{3912}{2} = 1956H. \quad (12)$$

$$P_2 = P_3 = \frac{P_1}{2} = \frac{1956}{2} = 978H.$$

( . )

« ».

1. . . . / . . . , . . .  
 . - . : , 1977. - 296 .
2. . . . / . . . - . :  
 , 1990. - 762 .
3. . . . - / . . . - . :  
 , 1988. - 216 .
4. . . . / . . . - . : , 1977. - 344 .

**References**

1. Trembovia V. Y. Teplotekhnicheskyye yspytaniya koteln kh ustanovok / V. Y. Trembovia, E. D. Fyhner. – M. : Enerhiya, 1977. – 296 s.
2. Staskevych N. L. Spravochnik po hazosnabzheniyu y yspolzovaniyu haza / Staskevych N. L. – L. : Nedra, 1990. – 762 s.
3. Iankelevych V. Y. Naladka haza-mazutnykh prom shlennykh kotelnykh / V. Y. Yankelevych. – M. : Enerhoatomyzdat, 1988. – 216 s.
4. Ravych R. B. Effektyvnost yspolzovaniya toplyva / Ravych R. B. – M. : Nauka, 1977. – 344 s.

/Peer review : 16.02.2018 .

/Printed :27.03.2018 .