

## EXPERIMENTAL RESEARCHING OF PENETRATION MATERIALS OF SHOE UPPERS USING LABVIEW SOFTWARE COMPLEX

*This paper presents the needle penetration materials used in the manufacture of shoe uppers pieces, namely the implementation of experimental studies piercing process details shoe uppers and processing of the results using the software complex LabVIEW. In carrying out experimental research efforts penetration of parts for the system "needle-detail-detail", defined by the following parameters: the applied moment; thick material parts. Researching of penetration was conducted on an experimental setup that allows to model processes that occur during stitching piece. Processing of experimental data allowed obtaining the regression equation determining needle penetration efforts in split leather and vinyl artificial leather. For natural value equation supplied to coded X factor in the equation and receiving function depending needle penetration force as part of the applied torque and thickness of parts of the shoe uppers. The resulting differences analytical calculations and research results due to the inevitable errors of experiment and mathematical model of some inconsistency, resulting in the analytical study adopted provisions for simplification.*

*Keywords: details of shoe uppers, experimental study, Lab VIEW, penetration.*

П.С. МАЙДАН, А.В. БУРЯК  
Хмельницький національний університет

### ЕКСПЕРИМЕНТАЛЬНІ ДОСЛІДЖЕННЯ ПРОЦЕСУ ПРОКОЛЮВАННЯ МАТЕРІАЛІВ ВЕРХУ ВЗУТТЯ З ВИКОРИСТАННЯМ ПРОГРАМНОГО КОМПЛЕКСУ LABVIEW

*Дана робота присвячена дослідженню процесу проколювання голкою матеріалів, які використовуються під час виготовлення заготовок верху взуття, а саме виконанню експериментальних досліджень процесу проколювання деталей верху взуття та обробці отриманих результатів з використанням програмного комплексу LabVIEW. При проведенні експериментальних досліджень зусилля penetрації деталей, для системи "голка – деталь – деталь", визначались наступними показниками: прикладеним моментом; товщиною матеріалу деталей. Дослідження процесу penetрації проводилось на експериментальній установці, яка дозволяла моделювати процеси, що відбуваються при зшиванні заготовки. Обробка експериментальних даних дозволила отримати рівняння регресії визначення зусилля penetрації голки в бахтармянний спилок та вінілштучкири. Для одержання натурального рівняння підставлялись значення кодованого фактора X у рівняння і отримували функцію залежності зусилля penetрації голки в деталь від прикладеного моменту та товщини матеріалу деталей заготовки верху взуття. Отримані розбіжності аналітичних розрахунків і результатів досліджень обумовлені неминучою помилкою експерименту, а також деякою невідповідністю математичної моделі, внаслідок прийнятих при аналітичному дослідженні положень для спрощення.*

*Ключові слова: деталі верху взуття, експериментальні дослідження, LabVIEW, проколювання.*

#### Introduction

In the experimental researching of the process of piercing (penetration) footwear details, the following materials: split leather GOST 1838-83 and TU 17-21-360-85 vinyl artificial [1]. For the experimental researching used equipment that allows the penetration process to implement parts of shoe uppers possibility of changing factors are learn and researched registration options.

During penetration previously stacked layers shoe upper details of the forces that could lead to their displacement. The shift detail will take place if the effort of penetration material would exceed efforts the fixing parts.

Process efficiency package penetration estimated one criterion: the lack of material parts offset relative to each other. Therefore, an experimental research task is to determine the values of effort penetration into the material details depending on the factors of the process in which the breach of details occurs. Determination of these parameters depends on the strength of fixing details, set the values defined contact area of the foot, speed of installation, material thickness details [2]. However, requires further research.

#### Analysis of researches and publications

To determine the parameter optimization and selection circuit design of experiment we conducted an analysis of prior information [3, 4]. Based on this analysis, according to [2], as a study option was selected the efforts needle penetration in detail. Selecting this option because the defects in the finished product associated with excessive force of needle point penetration in materials of light industry [5]. For the main factors selected parameters that occur in real processes needle penetration into the material, so the diameter and length of the needle should be constant and unchanged during the experiment.

Thus, for a system of "needle-detail-detail" during experimental research efforts penetration details defined by the following indicators: the applied moment; thick material parts.

The value of needle penetration force in the details material the experimental setup was determined by means of measuring and recording, such as using a computer.

#### The wording paper purposes

The objective of experimental researching is to obtain reliable values of efforts needle penetration shoe uppers of different materials using complex software Lab VIEW.

**The main material of researches**

Research of penetration was carried out on an experimental setup (fig. 1), which can simulate the processes occurring in the cross-linking of the shoe uppers.

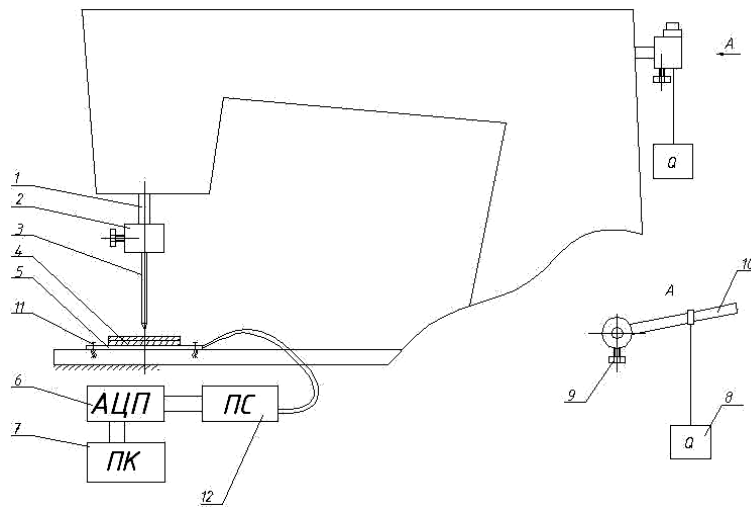

1 - needle driver; 2 - needle holder; 3 - needle; 4 - material; 5 - gage beam; 6 - analogue-to-digital converter; 7 - PC; 8 - load; 9 - screw; 10 - lever; 11 - screw; 12 - signal amplifier

**Fig. 1. Scheme of the experimental setup for determining needle penetration efforts in detail**

Installation for experimental researches work is as follows.

As a basis for research settings used sewing machine 23 class PMZ, which instead needle plate fixed gage beam (tenzobalka) 5. Needle 3 parts piercing material passing through the hole in gage beam, crushes the material, which in turn acts on gage beam and arching her changing cross-section sensors. Efforts penetration transmitted by applying the moment to lever 10 mounted on the flywheel sewing machine.

For the record the experimental conditions and processing of experimental data the factors level are encoded.

Adopted the following variable factors: X1 - attached moment; X2 - the thickness of the material details.

The plan provides coding values X1, X2, on three levels (+1, 0, -1) using the known expression [3, 4]. Factors and their coded values equal intervals and changes are summarized in table 1.

Table 1

**The levels and intervals factors changing**

Name	X1, kgs	Details material	
		Split leather GOST 1838-83	Vinyl artificial TU 17-21-360-85
		X2 <sub>1</sub> , m	X2 <sub>2</sub> , m
Changing interval	1	0,00035	0,00015
Factors level:			
- 1	1	0,0017	0,0018
0	2	0,00205	0,00195
+ 1	3	0,0024	0,0021

After the implementation of the matrix table 2 and obtaining values applied moment conducted the experimental data processing for noncomposition rotatable planning with two factors.

Table 2

**The matrix of planning and values of experiments**

X1	Value X1	X2	Value X2 <sub>1</sub>	Value X2 <sub>2</sub>	Result Y1	Result Y2
1.0	3.0	0.0	0.00205	0.00195	40.696	51.804
-1.0	1.0	0.0	0.00205	0.00195	38.107	50.591
0.5	2.5	0.866	0.0023062	0.0020597999	38.73	46.488
0.5	2.5	-0.866	0.0017469	0.0018201	33.923	37.53
-0.5	1.5	0.866	0.0023062	0.0020597999	37.967	42.508
-0.5	1.5	-0.866	0.0017469	0.0018201	28.924	37.794
0.0	2.0	0.0	0.00205	0.00195	35.556	62.58
0.0	2.0	0.0	0.00205	0.00195	35.488	66.171
0.0	2.0	0.0	0.00205	0.00195	37.666	63.462
0.0	2.0	0.0	0.00205	0.00195	35.829	69.349

The coefficients of the regression equation

The coefficients	Value for split leather GOST 1838-83	Value for vinyl artificial TU 17-21-360-85
b <sub>2</sub>	3.99803287745317	3.9466509069277436
b <sub>1</sub>	1.8233337402343759	1.0236670176188118
b <sub>0</sub>	36.13474941253662	65.39050006866455
b <sub>12</sub>	2.4455833435058594	2.4502003987630205
b <sub>11</sub>	3.2662359873453823	-14.193592707316085
b <sub>22</sub>	-2.758529027303055	-27.688419977823898

Conducted processing experimental data allowed to obtain regression equation for the first experimental determination efforts in needle penetration in the split leather GOST 1838-83:

$$y_1(x_1, x_2) = 36,135 + 1,824 \cdot x_1 + 3,99 \cdot x_2 - 2,445 \cdot x_1 \cdot x_2 + 3,266 \cdot x_1^2 - 2,76 \cdot x_2^2, \tag{1}$$

and the equation for the second experiment, determination effort penetration the vinyl artificial TU 17-21-360-85:

$$y_2(x_1, x_2) = 65,39 + 1,023 \cdot x_1 + 3,95 \cdot x_2 + 2,45 \cdot x_1 \cdot x_2 - 14,19 \cdot x_1^2 - 27,68 \cdot x_2^2, \tag{2}$$

where  $x_1, x_2$  – variable factors.

For natural equation substitute value of coded X factor in the equation (1) and obtain a depending function needle penetration force in detail of the applied torque and thickness details of the shoe uppers:

$$y_1(M, t) = 36,135 + 1,824 \cdot \frac{(M-1)}{2} + 3,99 \cdot \frac{(t-0,0017)}{7e^{-4}} - 2,445 \cdot \frac{(M-1)}{2} \times \frac{(t-0,0017)}{7e^{-4}} + 3,266 \cdot \left(\frac{(M-1)}{2}\right)^2 - 2,76 \cdot \left(\frac{(t-0,0017)}{7e^{-4}}\right)^2 \tag{3}$$

$$y_2(M, t) = 65,39 + 1,023 \cdot \frac{(M-1)}{2} + 3,95 \cdot \frac{(t-0,0018)}{2,99e^{-4}} + 2,45 \cdot \frac{(M-1)}{2} \times \frac{(t-0,0018)}{2,99e^{-4}} - 14,19 \cdot \left(\frac{(M-1)}{2}\right)^2 - 27,68 \cdot \left(\frac{(t-0,0018)}{2,99e^{-4}}\right)^2 \tag{4}$$

where  $M$  – applied torque;  
 $t$  – thickness details of the shoe uppers.

$$M := 4 \quad t := 1..3$$

$$y(M,t) := 36.135 + \left(1.824 \cdot \frac{M-1}{2}\right) + \left(3.99 \cdot \frac{t-0.0017}{7 \cdot e^{-4}}\right) - \left(2.445 \cdot \frac{t-0.0017}{7 \cdot e^{-4}} \cdot \frac{M-1}{2}\right) + \left[3.266 \cdot \left(\frac{M-1}{2}\right)^2\right] - \left[2.76 \cdot \left(\frac{t-0.0017}{7 \cdot e^{-4}}\right)^2\right]$$

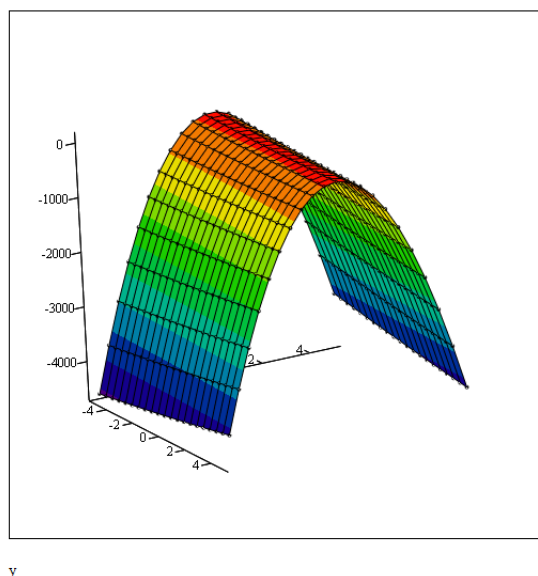

Fig. 2. Analytical calculation of regression equations for material split leather GOST 1838-83 at constant moment and thickness of various details of the package, the software environment Matcad

The resulting of the regression equation (3) and (4) allow describing the process of penetration of the needle into the details shoe uppers with two factors - the applied torque and thickness (fig. 2).

Planning experiments and experimental researches were carried by using a shareware program OptimizationModel & PlanningExperiment-02.041 "[6].

Removing the travelling values from sensor and record them on a PC is made by using Lab VIEW, which provides the inextricable link between theoretical calculations and experimental researches [7–9].

Full integration environment for signal processing Lab VIEW and environment to develop electronic schemes Multisim allows you to design electrical circuits and devices that implement them on NI ELVIS breadboard and conduct testing with real signals in Lab VIEW.

This approach allows completely under a single platform National Instruments, lock the development cycle of electronic devices, including electronic circuit simulation, prototyping and product testing with its real test and measurement equipment.

Block diagram (fig. 3), which will be held from ADC signal processing program Lab VIEW 8.5, the first application opens a port number which is set element 1 through module 2. Further information on the open port goes to control the flow of data from the ADC 6, which is used to configure fields: 3 - it indicates the number of ADC channels from which to read data; 4 - it specifies the frequency with which reading data is made entering the open channels; 5 - it indicates the amount of data that is displayed in an array of module 6; 14 - it specified settings channels are removed from the data. Array data, conversion element array values in the processed signal is converted into data stream that is easier to handle, display in graphic indicator 18 and recorded for analysis by block 12. Because the data are captured in the form of an electrical signal that has any particular value, proportional to the measured physical quantity, it should be calibration at first.

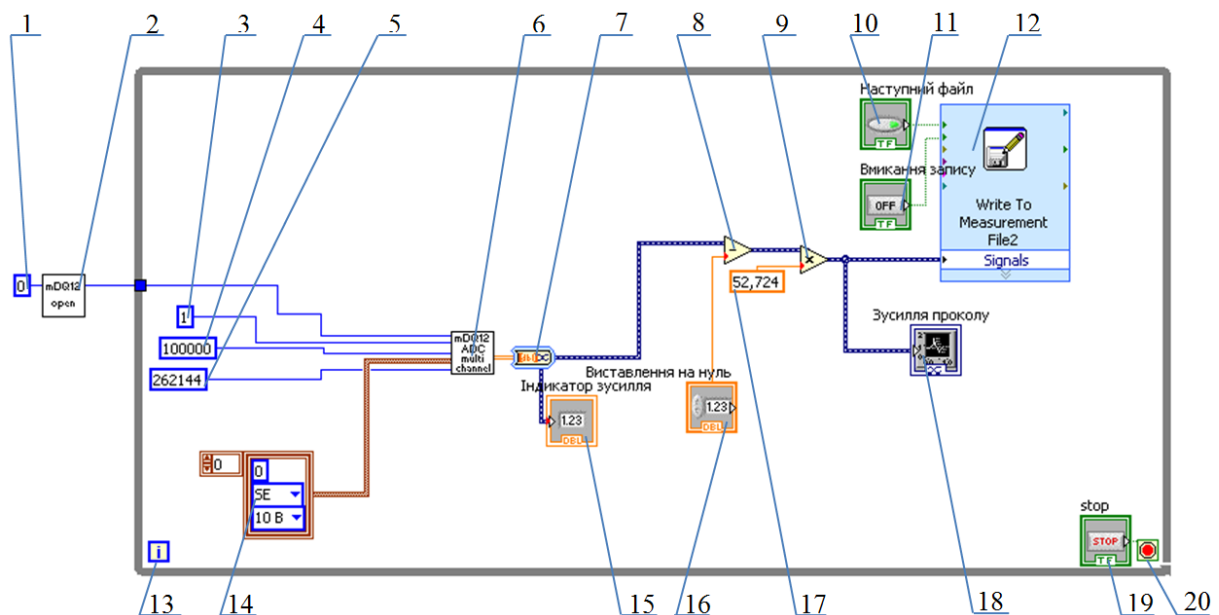

1, 3, 4, 5, 17 - element default constant values, 2 - control port analogue-to-digital converter (ADC), 6 - control the flow of data from the ADC, 7 - element converting an array of values in the processed signal, 8, 9 - element arithmetic conversions, 10, 11, 19 - button process control applications, 12 - unit record values in the file, 13 - counting cycle, 17 - element correction signal values, 18 - a graphical indicator,

19 - digital display, 20 - element of the cycle

Fig. 3. Block Diagram program virtual appliance for processing signals of two channels

Calibration by using arithmetic transformation element 9 and calibration coefficient recorded in field 17. With arithmetic operation subtraction element 8 signals is set to zero. After the necessary changes the signal goes to block entry of values in file 12, which is guided buttons 10 and 11. To stop the program is using the button 20.

The graph (Fig. 5) it is clear that experimental and analytical values are adequate, the deviation does not exceed 5%. The resulting differences analytical calculations and research results due to the inevitable errors of experiment and mathematical model of some inconsistency, resulting in the analytical study adopted provisions for simplification.

**Summary.** Experimental researching with using software complex Lab VIEW, showed high precision of the results and ease of them processing. The resulting current efforts graphics penetration material with sufficient accuracy to meet the theoretical efforts penetration graphs, which in turn allows confirming the need for complex software with Lab VIEW conducted research. Using software system opens up possibilities for performed experimental research and allows simultaneous lifting of current data from several connected sensors and their processing; it will improve the accuracy in conducting experimental research.

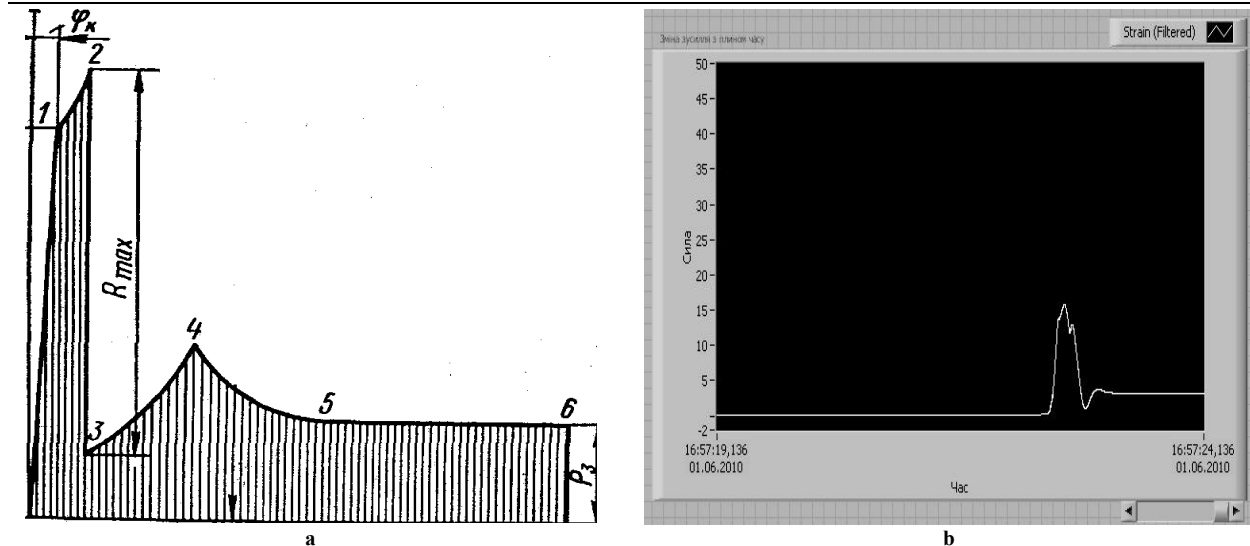

Fig. 4. Figure effort needle penetration material: a - theoretical graph; b - graph obtained experimentally using LabVIEW

Graphical interpretation of research results on fig. 5.

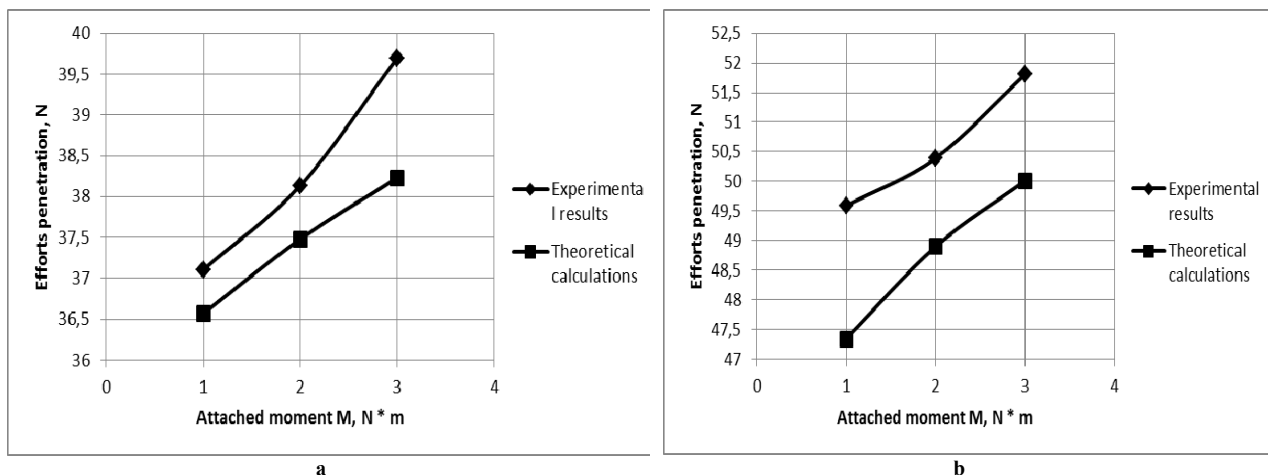

Fig. 5. Graph of the force applied to penetration point on the main shaft material thickness  $t = 0,00205$  m to split leather GOST 1838-83 (a) for vinyl artificial TU 17-21-360-85 (b)

## References

1. Shkira zavzhdy aktualna. URL : <http://megasite.in.ua/110794-shkira-zavzhdi-aktualna.html>
2. Maidan P.S. Udoskonalennia protsesu avtomatyzovanoho skladannia zahotovok verkhу vztuttia z vykorystanniam universalnogo prystosuvannia : dys. ... kand. tekhn. nauk : 05.18.18 «Tekhnolohiia vztuttia, shkirianykh vyrobiv i khutra» / P.S. Maidan – Khmelnytskyi : KhNU, 2013. – 173 s.
3. Planirovanie eksperimenta v tehnologicheskikh issledovaniyah. Vinarskiy M. S., Lure M. V. – K. : "Tehnika", 1975. – 168 s.
4. Yascheritsyn P.I., Maharinskiy E.I. Planirovanie eksperimenta v mashinostroenii: Sprav. Posobie. – Vyish. Shk., 1985. – 286 s.
5. Tonkovid L.A. Avtomatizatsiya sborochnykh protsessov v obuvnom proizvodstve. – K. : Tehnika, 1984. – 248 s.
6. Prohrama dlia planuvannia esperimentalnykh doslidzhen "OptimizationModel&PlanningExperiment-02.041". URL : <http://mdop.sourceforge.net/>
7. Suranov A.Ya. LabVIEW 8.20: spravochnik po funktsiyam / Suranov A.Ya. – M. : DMK Press, 2007. – 536 s.
8. Vinogradov N.A. Razrabotka prikladnogo programmnoho obespecheniya v srede LabVIEW : [ucheb. posobie]. / Vinogradov N.A., Listratov Ya.I., Sviridov E.V. – M. : Izdatelstvo MEI, 2005. – 47 s.
9. LabVIEW: praktikum po osnovam izmeritelnykh tehnologiy: ucheb. posobie dlya vyissh. ucheb. zaved. / [Batorvin V.K., Bessonov A.S., Moshkin V.V., Papulovskiy V.F.]. – M. : DMK Press, 2005. – 208 s. : il.

Рецензія/Peer review : 7.11.2015 р.

Надрукована/Printed :28.10.2016 р.

Рецензент: д.т.н., професор Славінська А.Л.