

CURRENT CHALLENGES OF SCIENCE AND EDUCATION

Proceedings of IV International Scientific and Practical Conference
Berlin, Germany
11-13 December 2023

**Berlin, Germany
2023**

UDC 001.1

The 4th International scientific and practical conference “Current challenges of science and education” (December 11-13, 2023) MDPC Publishing, Berlin, Germany. 2023. 592 p.

ISBN 978-3-954753-05-5

The recommended citation for this publication is:

Ivanov I. Analysis of the phanistic composition of Ukraine // Current challenges of science and education. Proceedings of the 3rd International scientific and practical conference. MDPC Publishing, Berlin, Germany. 2023. Pp. 21-27. URL: <https://sci-conf.com.ua/iii-mizhnarodna-naukovo-praktichna-konferentsiya-current-challenges-of-science-and-education-13-15-11-2023-berlin-nimechchina-arhiv/>.

Editor

Komarytskyy M.L.

Ph.D. in Economics, Associate Professor

Collection of scientific articles published is the scientific and practical publication, which contains scientific articles of students, graduate students, Candidates and Doctors of Sciences, research workers and practitioners from Europe, Ukraine and from neighbouring countries and beyond. The articles contain the study, reflecting the processes and changes in the structure of modern science. The collection of scientific articles is for students, postgraduate students, doctoral candidates, teachers, researchers, practitioners and people interested in the trends of modern science development.

e-mail: berlin@sci-conf.com.ua

homepage: <https://sci-conf.com.ua>

©2023 Scientific Publishing Center “Sci-conf.com.ua” ®

©2023 MDPC Publishing ®

©2023 Authors of the articles

107. *Тищенко С. Є., Рудніченко М. Д.* 529
ТЕХНІЧНІ ОСОБЛИВОСТІ РЕАЛІЗАЦІЇ МОДУЛЯ АНАЛІЗУ
ПОВЕДІНКОВОЇ АКТИВНОСТІ КОРИСТУВАЧІВ ВЕБ-
ЗАСТОСУВАНЬ
108. *Токарчук В. В., Тупиця О. М.* 533
АНАЛІЗ ПРИДАТНОСТІ ВІДХОДІВ ФЕРРОСПЛАВНОГО
ВИРОБНИЦТВА В ЦЕМЕНТНІЙ ПРОМИСЛОВОСТІ
109. *Фашевський А. В., Загоруйко М. Ю.* 539
ЗАСТОСУВАННЯ SAN-ШИНИ В ПРОЦЕСІ МОДЕРНІЗАЦІЇ
ЗАЛІЗНИЧНОГО ТРАНСПОРТУ
110. *Федотов С. О.* 544
НЕЕФЕКТИВНІ АРХІТЕКТУРНІ РІШЕННЯ ПОБУДОВИ
ІНФОРМАЦІЙНИХ СИСТЕМ В ХМАРНИХ СЕРВІСАХ
111. *Ялова А. М., Шаповалова О. О.* 549
АНАЛІЗ СВІТОВОГО ДОСВІДУ ВПРОВАДЖЕННЯ НОВОГО
ТЕПЛО ГЕНЕРУЮЧОГО ОБЛАДНАННЯ
112. *Ялова А. М., П'ятаков К. С.* 553
МОДЕРНІЗАЦІЯ КОНСТРУКЦІЇ ВОДОГРІЙНОГО КОТЛА ДЛЯ
БІЛЬШ ЕФЕКТИВНОГО СПАЛЮВАННЯ РІЗНИХ ВИДІВ
ТВЕРДОГО ПАЛИВА

PHYSICAL AND MATHEMATICAL SCIENCES

113. *Poplavska O.* 560
PERIODIC REINFORCEMENT OF THE PRESTRESSED STRIP
WITH ELASTIC RECTANGULAR ADJUSTMENTS
114. *Коробчук Ю. В., Лановенька Д. С.* 565
СУТНІСТЬ НЕРІВНОСТІ КОШІ
115. *Нагребельна І. А.* 568
ВАЖЛИВІСТЬ ДИДАКТИЧНОЇ ГРИ НА УРОКАХ
МАТЕМАТИКИ

GEOGRAPHICAL SCIENCES

116. *Гордієнко П. В.* 574
ЗАСТОВУВАННЯ БПЛА В АГРОСЕКТОРІ УКРАЇНИ: СТАН ТА
ПЕРСПЕКТИВИ
117. *Єрмаков В. В., Бутенко О. С.* 580
ЛАНДШАФТНО-ГЕОГРАФІЧНІ ОСОБЛИВОСТІ ФОРМУВАННЯ
ЕКОЛОГІЧНОЇ МЕРЕЖІ ПОЛТАВСЬКОЇ ОБЛАСТІ
118. *Кравчинський Р. Л., Корчемлюк М. В., Стефурак О. М.* 584
ВОДНІ ДЖЕРЕЛА ЯК ІНДИКАТОР АКТИВІЗАЦІЇ ЗСУВНИХ
ПРОЦЕСІВ У ПІВДЕННО-СХІДНИХ КАРПАТАХ
119. *Майнов О. О., Юрасов С. М.* 591
МІНЛИВІСТЬ ЯКОСТІ ВОД І ЇЇ ВРАХУВАННЯ ПРИ ОЦІNKИ
ЯКОСТІ ПОВЕРХНЕВИХ ВОД (НА ПРИКЛАДІ РІЧОК ДНІСТЕР
І ДУНАЙ)

PHYSICAL AND MATHEMATICAL SCIENCES

УДК 514.85

PERIODIC REINFORCEMENT OF THE PRESTRESSED STRIP WITH ELASTIC RECTANGULAR ADJUSTMENTS

Poplavska Olena

Senior Lecturer

Khmelnytsky National University

Khmelnytskyi, Ukraine

Abstract. In the article, within the framework of the linearized theory of elasticity, the law of influence of initial (residual) stresses on the distribution of contact stresses in an elastic strip reinforced by periodically placed elastic rectangular overlays investigated. The study carried out in general for large (finite) initial deformations in the case of elastic potentials of an arbitrary structure.

Keywords: contact problems, linearized elasticity theory, initial (residual) stresses.

Introductions. In the article, within the framework of the linearized theory of elasticity, the law of influence of initial (residual) stresses on the distribution of contact stresses in an elastic strip reinforced by periodically placed elastic rectangular overlays is investigated. The study was carried out in general for large (finite) initial deformations in the case of elastic potentials of an arbitrary structure.

The studies carried out and published in this article are of significant national economic importance. Which consist in the development of a methodology for taking into account the regularities of the influence of initial (residual) deformations on the law of distribution of contact forces with an assessment of the need to take into

account these effects in engineering calculations when calculating the latter for strength. This problem is especially acute now, when it is necessary to improve the reliability of machines in various branches of modern industry with a simultaneous reduction in their material consumption and the conservation of energy resources for their manufacture.

Improving the reliability and durability of engineering structures and machines is one of the most urgent tasks of modern construction and mechanical engineering. Its successful solution largely facilitated by extensive scientific research in the field of mechanics of a rigid deformed body, in particular in the study of the problem of load transfer in structures and machine parts. The emergence of new materials, the need to increase operational structures and machines, reduce their weight, increase their service life, reduce cost and achieve economic compatibility - all this depends on the calculation methods.

Aim. Investigation of the influence of initial (residual) stresses on the law of distribution of contact stresses along the contact line supported by elastic face linings.

Materials and methods. The study of the distribution of contact stresses along the contact segments of periodically placed elastic overlays with an elastic isotropic half-plane and a strip in the classical theory of elasticity is devoted to the works of A.N. Guz, in the case of the linearized theory of elasticity – the works of V.S. Sargsyan, V.B. Rudnytsky, M.M. Dikhtiaruk, and others.

The problem of transferring an arbitrarily distributed load (Fig. 1) from periodically placed thin overlays to an elastic strip with initial stresses pinched by one face is considered.

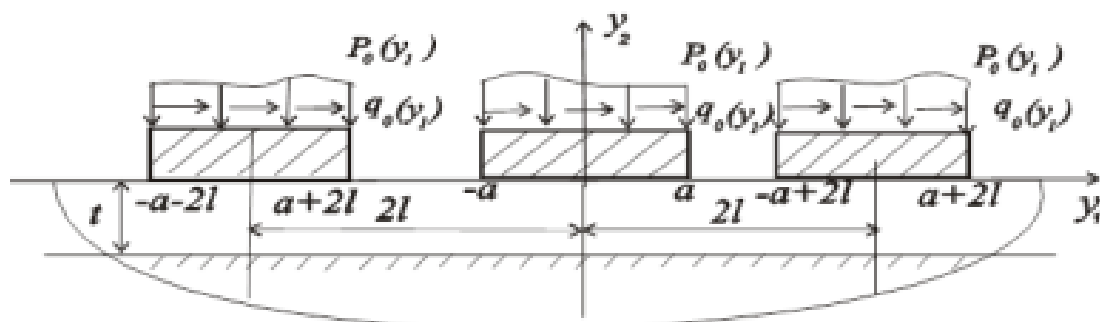

Fig. 1

The solution of the problem reduced to the solution of a singular integro differential equation with a Hilbert kernel, which can be represented as the sum of two nuclei: a special part and a regular part [1, 2].

The desired solution is presented in the form of a series on Jacobi polynomials, and to determine the unknown coefficients of the series, a quasi-regular infinite system of algebraic equations is obtained [3, 4]

$$l_m \tilde{X}_m + \sum_{n=1}^{\infty} [P_{m,n}^{(1)} \tilde{X}_n + P_{m,n}^{(2)} \tilde{X}_n] = -[P_m^{(1)} \tilde{X}_0 + P_m^{(2)} \tilde{X}_0 + P_m^{(3)} + R \cdot P_m^{(1)}] \quad (m=1,2,\dots).$$

Based on calculations, graphs given that characterize the influence of initial stresses in the contact area of periodically placed linings (Fig. 2).

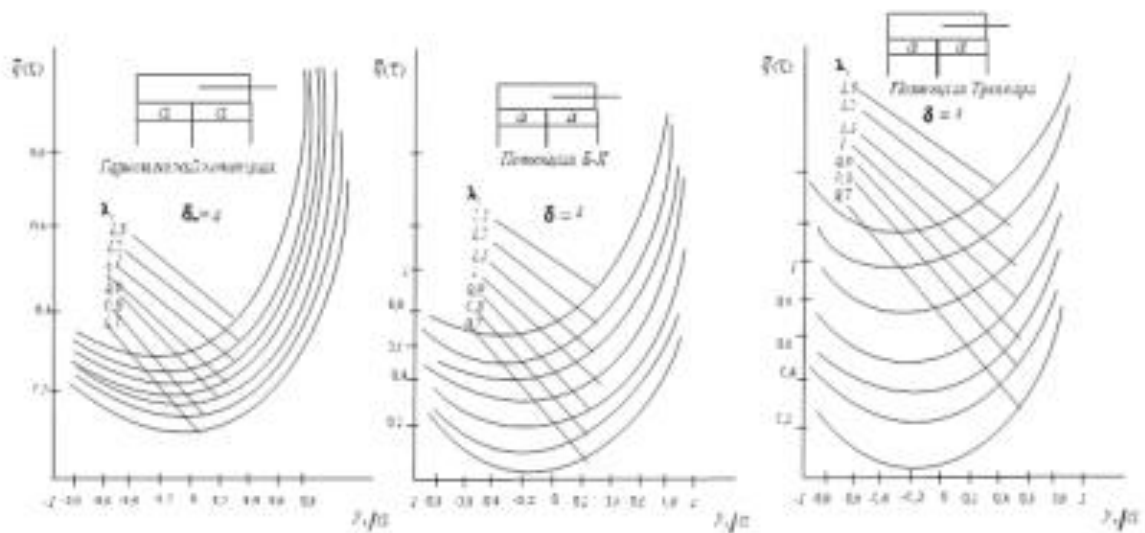

Fig. 2

These figures illustrate the effect of initial (residual) stresses in an elastic strip on the law of distribution of contact stresses under periodically placed overlays from the action of tangential force $q_0(y_1) = Q_0$ for dimensionless quantities.

The graphs show the location of curves for the value of the parameter $\lambda_1 = 1,3; 1,2; 1,1; 1; 0,9; 0,8; 0,7$ – which characterizes the initial (residual) stress-strain state. The value $\lambda_1 = 1$ corresponds to the elastic band without initial (residual) stresses and represented on the graphs by a dotted line, i.e. the value of contact stresses for a similar problem solved within the framework of the classical theory of

elasticity [5].

It follows from the graphs that the regularity of the influence of initial stresses in the elastic band on the distribution of contact tangential stresses significantly depends on the structure of the elastic potential in the latter. Initial stresses have a significant quantitative influence in highly elastic materials compared to rigid ones, and the qualitative effect is the same. When ($\lambda_1 < 1$) compressed, contact stresses decrease, and in the case of tension ($\lambda_1 > 1$), they increase. This result can be used effectively to adjust contact forces in strength analysis of structures.

Conclusions. In this work, the theory of contact interaction of elastic overlays of finite length with an elastic strip is further developed, taking into account the initial (residual) stresses. Within the framework of the linearized theory of elasticity, the problems of contact interaction of an elastic strip with initial (residual) stresses supported by elastic curve overlays are formulated, in a general form for the theory of large (finite) and two variants of small initial (residual) deformations in the case of an arbitrary structure of elastic potential. The basic singular integro-differential equations of the class of problems under consideration are obtained, the solution of which is presented in the form of quasi-regular infinite systems of algebraic equations.

REFERENCES

1. Rudnitsky, V. B., Dikhtyaruk N. N. A contact problem about the interaction of an infinite stringer and two identical strips with initial stresses. / V. B. Rudnitsky, N. N. Dikhtyaruk, N. N. // Prikl. Mechanics, 2017, – 53, No 2, – P. 41 – 48. class of problems under consideration, the solution of which is presented in the form of quasi-regular infinite systems of algebraic equations
2. Dikhtyaruk, N. N. Equilibrium of a prestressed strip reinforced with elastic plates // International Applied Mechanics. – March 2004, Volume 40, Issue 3, pp 290–296.
3. Rudnitskii V. B., Dikhtyaruk N. N. Interaction Between an Infinite Stringer and Two Identical Prestressed Strips: Contact Problem /, V.B. Rudnitskii, N.N Dikhtyaruk // Translated from Prikladnaya Mekhanika, Vol. 53, No. 2,

pp. 41-48, March–April, 2017.

4. Dikhtiaruk, M. M., Poplavskā, O. A. "Analogue of the Melan problem for an elastic strip with initial stresses with a reinforced elastic overlay" [Text] / M. M. Dikhtiaruk, O. A. Poplavskā // Problems of tribology. – 2018. – №1. P. 37-42.

5. Саркисян В. С. Контактные задачи для полуплоскостей и полос с упругими накладками. – Ереван: Изд. Ереван. ун-та, 1983. – 260 с.