

Design Methodology to Construct Information Measuring Systems Built on Piezoresonant Mechanotrons with a Modulated Interelectrode Gap

Alla Taranchuk and Sergey Pidchenko
*Khmelnytsky National University,
Ukraine*

1. Introduction

One of the perspective tendencies of development of information measuring systems is applying the sensors of physical magnitudes on basis of quartz resonators (QR) of special type, the stimulation of piezoelement in which is accomplished in the vacuum or filled with dielectric gap. The changes of geometry (modulation) of the gap between piezoelement and electrode (electrodes) of quartz resonator leads to the shift of personal resonance frequencies of QR, as well as the oscillatory system in general, the part of which it is. Despite some substantial advantages of presented way of QR control, piezoresonance sensors (PRS) of given type were not widely used, which, to the authors' opinion, is caused by inappropriate study of theoretical and practical material of construction of PRS of given type. The material of present chapter fills in the gap in the study.

Present chapter covers the theoretical issues, projecting and applying in highly informative measuring systems of piezoresonator with modeled under the influence of mechanical force the interelectrode gap and mobile electrode in the form of membrane, which is named piezoresonance mechanotron (PRMT) (Kolpakov et al., 2009). We present mechanic scheme of PRMT, examine its basic constructive and electrical characteristics, describe the regimes of movement of mobile electrode. We propose approximate method of linearization of graduation characteristic characteristics of PRMT while its use in primary measuring transducers nonelectric magnitudes. Mechanic scheme, mathematical model and the results of numeric simulation of a PRMT membrane bending flexure using ANSYS - programme and a thermal PRMT model as well as numeric MATHLAB/ FEMLAB - analyses of temperature - frequency characteristics under the excitation power variation of a PRMT piezoelement and outer temperature change are presented. We present real life piezoresonance mechanotron designs to be used as high precision surplus air pressure transducers and the results of the development research of their precision characteristics. Examples of PRMT applications as well as methods of secondary transducing of its output signals in real life information measuring systems to define human hemodynamic parameters are presented.

2. Quartz resonator as an element of precision primary measuring transducers of nonelectric magnitudes - Quartz resonator frequency control

Quartz resonator (QR) represents electro - mechanical oscillatory system, conventional equivalent scheme of which is shown in Fig. 1. Dynamic elements L_1 - equivalent inductivity, C_1 - equivalent capacity and R_1 - equivalent resistance of losses are caused by presence of direct and reverse piezoeffects and resonance peculiarities of piezoelement in quartz resonator. As the quality factor of quartz resonators is very high and comprises tens and hundreds thousands for usual resonators and several millions for precision ones, equivalent dynamic branch of quartz resonator has a sense only in narrow band of frequency next to resonance, and in other area of frequency equivalent electric resistance of QR is determined by static capacity C_0 (Cady, 1946).

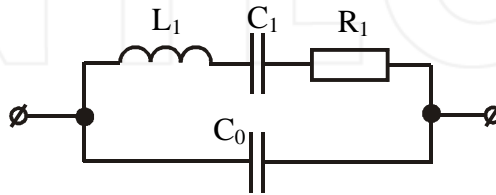

Fig. 1. Equivalent scheme of quartz resonator

The basic parameters of quartz resonator are the frequencies of successive and parallel resonance

$$f_1 = \frac{1}{2\pi\sqrt{L_1 C_1}} \text{ and } f_a = f_1 \sqrt{1+m}; \quad (1)$$

the quality factor and the width of interresonance interval

$$Q = \frac{2\pi f_1 L_1}{R_1} = \frac{1}{2\pi f_1 C_1} \text{ and } \frac{f_a - f_1}{f_1} \approx 0.5m, \quad (2)$$

where $m = C_1/C_0$ - is capacity factor.

At the same time dynamic inductivity L_1 is connected with equivalent mass of QR, and the dynamic capacity C_1 is connected with elastic peculiarities (equivalent compliance).

Control the frequency in using QR as the piezoresonant sensor of physical magnitudes, as it can be seen from the analyses of equivalent resonator circuit, can be realized:

- by the influence on equivalent compliance (C_1) or on equivalent mass (L_1) of oscillatory system or on both mentioned parameters at the same time. In accordance with (1) in this case both resonance frequencies are varied;
- by the varieties of active losses (R_1). Increasing the decrement of damping $\delta = 1/Q$, as is known, decreases the frequency own oscillations in accordance with the correlation $w = \sqrt{w_0^2 - \delta^2}$.

- by managing the meaning of value of inter- electrode capacity C_0 or capacity correlation $m = C_1/C_0$.

The first method, which is based on the modulation of equivalent compliance C_1 or the mass L_1 of oscillatory system, is widely used in piezoresonant sensors (PRS) of pressure, micromoving, microweighing, humidity, gas analysis and others (Malov, 1989; Kolpakov & Pidchenko, 2011).

As for construction of PRS the high quality factor resonators are used, in which the decrement of damping is so small that it does not practically influence the resonance frequencies, the second method of managing on frequency did not find wide application.

The third method is interesting from the point of view of applying in resonators of special type (piezoresonant mechanotron), in which between piezoelement and electrode (electrodes) there is the gap, vacuum-processed or filled with material with dielectric permeability ε . Changes of gap geometry (modulation), as well as varying its electric characteristics, leads to the shift of resonance frequency of oscillatory system as a whole.

The given way, in comparison with the first, in some cases has certain advantages, for example, at measurements of micromovings and physical magnitudes led by it. It is connected with an exception of direct mechanical influences on a sensor piezoelement that leads to change (deterioration) of its characteristics as highly quality and highly stable element of oscillatory system of the quartz crystal oscillator.

3. Design methodology of piezoresonant mechanotrons built on quartz resonators with a modulated interelectrode gap

Introduced PRMT is related to measuring converters with control of its resonance frequency by changing magnitude of gap between launch electrodes of piezoelectric element (PE).

Change of parameters of oscillatory system under action physical magnitude (moving and reducible magnitude) is used in PRMT. PRMT design map is shown in Fig. 2, (a), where x_0 - initial gap; x_m - magnitude stroke mobile electrode (membrane); $x = x_0 - x_m$ - current value of modulated interelectrode gap (Kolpakov F., Pidchenko S., Taranchuk A., et al, 2009).

Connection of capacitive parasitics with minor gap capacity enabled to reduce influence on the resonance frequency of oscillatory system. Modulated gap application, i.e. measuring capacitor connection inwards construction allows raising capacitive-ratio, and therefore tuning range of oscillatory system.

Piezoresonant mehanotron with modulated interelectrode gap (PRMT with MIG) equivalent electric circuit is shown in Fig. 2, (b). Following descriptions are made: L_1, R_1, C_1 - PE dynamic equivalent parameters on the fundamental mode of the thickness-shear vibrations; C_{PE} - PE static capacity; C_1/C_{PE} - capacitive ratio (for AT-cut crystal $m = (4...7) \cdot 10^{-3}$); $C_0 = C_m + C_{par}$ - capacitive parasitics with mounting capacity.

Rather important is the fact, that parasitic capacitive is connected through small capacitive gap and therefore it has little influence onto resonance frequency oscillatory system.

PRMT by its electric equivalent circuit is similar to any capacitor the operated quartz resonator. However, the use of modulated gap, e.i. connection of measuring compensator into the construction, gives the chance to increase considerably the capacitor relation, and therefore, the band of oscillatory system restructure. For example, on frequency 10 MHz under the gap modulation we can get the frequency deviation (25...30) kHz.

Let's define PRMT characteristics. Circuit equivalent resistance is:

$$Z = \frac{R_1 k_1 + j\omega L_1 k_2 - \frac{j}{\omega} k_4}{j\omega C_0 \left(R_1 (1 + C_{PE} k_3) + j\omega L_1 (1 + C_{PE} k_3) + j \left(\frac{C_{PE}}{C_0 C_1} + \frac{k_5}{\omega} \right) \right)}, \quad (3)$$

where $k_1 = 1 - \frac{C_{PE}}{C_g}$; $k_2 = 1 + \frac{C_{PE}}{C_g}$; $k_3 = \frac{1}{C_g} - \frac{1}{C_0}$; $k_4 = \frac{1}{C_1} + \frac{1}{C_g} + \frac{C_{PE}}{C_g}$;
 $k_5 = \frac{1}{C_0} - \frac{1}{C_g} - \frac{1}{C_1} - \frac{C_{PE}}{C_g C_1}$ - coefficients.

In conditions of a resonance $I_m(Z) = 0$, we obtain:

$$n_4 \omega^4 + n_2 \omega^2 + n_0 = 0, \quad (4)$$

where $n_4 = L_1 C_0$, $n_2 = \frac{C_{PE} R_1^2 (C_0 - C_g)}{L_1 (C_g + C_1)}$, $n_0 = \frac{C_0}{C_1 L_1 C_g}$.

Solving (4) for ω^2 can be written as follows:

$$\omega_{r,a}^2 = \frac{C_{PE} R_1^2 (C_0 - C_g)}{2 C_0 L_1 (C_1 + C_g)} \pm \frac{1}{2 L_1 C_0} \sqrt{\left(\frac{C_{PE} R_1^2 (C_0 - C_g)}{L_1 (C_g + C_1)} \right)^2 - \frac{4 C_0^2}{C_1 C_g}}. \quad (5)$$

For typical valuations of QCR parameters: $R_1 = 10$ Ohm, $C_1 = 22$ pF, $L_1 = 11,5$ μ H, $C_0 = (1...10)$ pF, $C_{PE} = (2...3)$ pF, $C_b = (0.1...1)$ pF. On basis of measurement results characteristics of QR control are built. They are shown in Fig. 3.

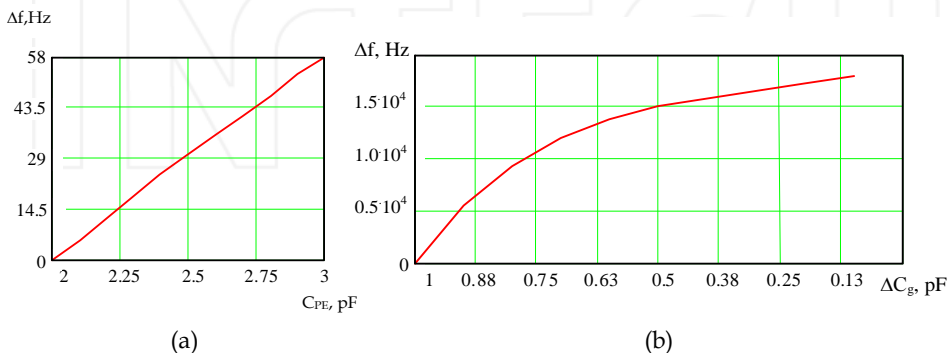

Fig. 2. (a) Dependence of absolute detuning on C_{PE} ; (b) Dependence of absolute detuning on ΔC_g

The analysis of received dependence shows, that the use of frequency control with the help of interelectrode gap rather effective and under little changes of volume of clearance allows to get information deviation of frequency of order of tens KHz.

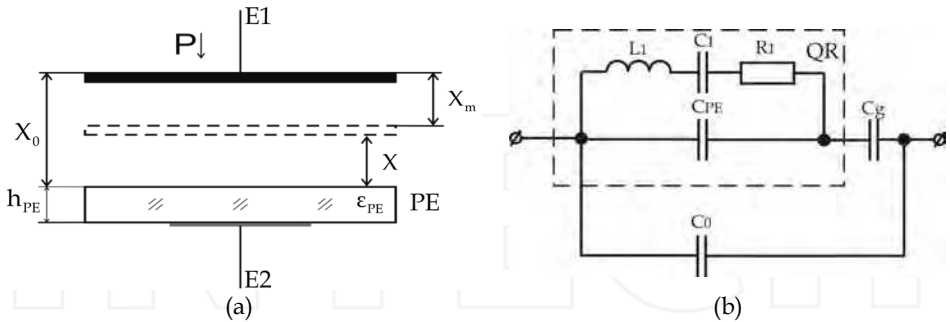

Fig. 3. (a) PRMT with MIG design map; (b) Equivalent electric circuit of PRMT

For real PRMT with piezoresonator AT - cut (diameter of piezoelement $d_{PE} = 18$ mm, electrode diameter is $d_e = 8$ mm, nominal frequency of piezoelement $f_n = 10.0$ MHz, $F_0 = 6500$ Hz) experimentally was received modulation (graduation) characteristic, shown in Fig. 4.

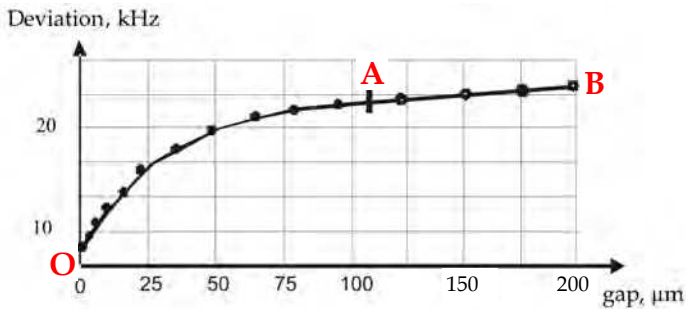

Fig. 4. Graduation characteristic of PRMT with MIG

It is obvious that it can be symbolically divided into two sectors (see Fig. 4). The first one, OA - is the area with maximum deviation and nonlinearity. The second one, AB - is the linear area of the curve, which is characterized by relatively small frequency changes. This allows to talk about two working conditions of PMRT: nonlinear and linear. The work in nonlinear conditions allows to achieve maximum resolution capability, in linear - maximum linearity of modulation characteristic under the demodulation of measuring signal by the linear frequency detector. Using PE in PMRT of pressure it is reasonable to use nonlinear conditions, which provides maximum sensitivity of PMRT, but allows to linearity graduation characteristic.

As opposed to PMRT it is possible to use external capacitive frequency control (ECFC), under which in the capacity of sensor the capacitive sensitive element, playing a role of C_g , is used.

We propose the comparative characteristic of external capacitive frequency control and control of modulation of interelectrode gap.

Equivalent electric circuit of QR with ECFC shown in Fig. 5. Standard piezoresonator is used and is connected sequentially with tuning inductance L_t and capacitive sensor of pressure $C_t(p)$ (see Fig. 5).

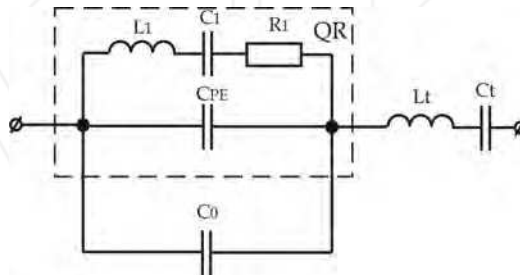

Fig. 5. Equivalent electric circuit of QR with external capacity control

Comparing Fig. 1, (a) and Fig. 5, we can mark, that parasitic capacitance C_0 , including also capacitance of assembling, on schemes it is included on a miscellaneous. Under external capacitive control it is connected parallel to static capacitance of PE. As frequency deviation is directly proportional to the capacitor relation

$$m = \frac{C_1}{C_{PE}} = \frac{C_1}{C_{PE} + C_0}, \quad (6)$$

so controlling the oscillatory system with an increase C_0 considerably worsens.

As controlling the modulation of interelectrode gap C_0 (see Fig. 2) is connected through small capacitance of gap and practically does not influence the size of static capacitance, i.e.

$$m' = \frac{C_1}{C_{PE}}. \quad (7)$$

From here a relative benefit on controllability of a variant with gap modulation

$$k_c = \frac{m'}{m} = 1 + \frac{C_0}{C_{PE}}. \quad (8)$$

This fact is confirmed by the calculation of deviation of frequency for two types of control according to formulae (5) (see Fig. 6).

Comparing these two types of control (see Fig. 6) shows multiple benefit of PMRT on the conversion conductance and the preference of its use. At this time in some devices of not high accuracy, for their reduction in price, the ECFC can also be used (Pidchenko, Kolpakov, Akulinichev, 2000).

4. Linearization of a PRMT modulation characteristic based on fractional-linear approximation of graduation characteristic

Having written down (5) in terms of graduation characteristics, we'll receive expression for resonant frequency PRMT:

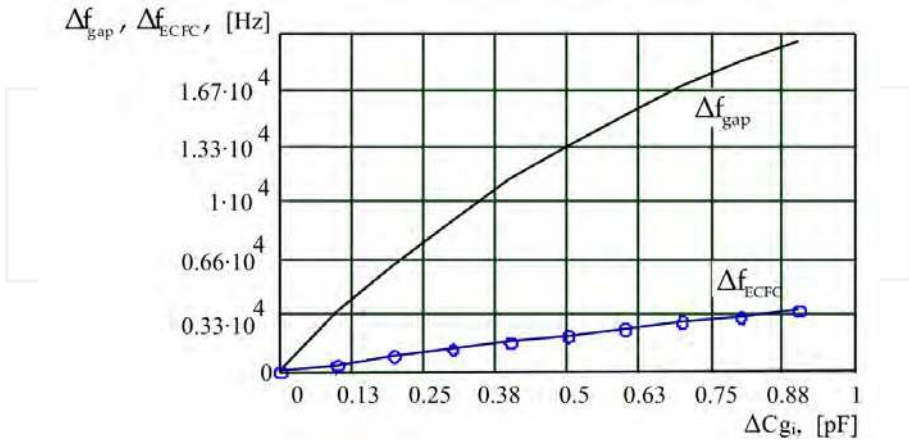

Fig. 6. Frequency mismatches comparison of ECFC and PRMT with MIG

$$f(x) = f_0 \sqrt{1 + \frac{m}{1 + \frac{h_{PE}}{\varepsilon_{PE}x}}} \approx f_0 \left[1 + \frac{0.5m}{1 + \frac{h_{PE}}{\varepsilon_{PE}x}} \right], \tag{9}$$

where f_0 - frequency rating of oscillating system with $x=0$, m - capacity ratio; h_{PE} - PE dimension which determine frequency (thickness); ε_{PE} - dielectric conductivity of PE material; x - current gap value.

Let us introduce the PE parameter $a = \frac{h_{PE}}{\varepsilon_{PE}} = \frac{N}{f_0 \varepsilon_{PE}}$, where N - is frequency coefficient (for AT cut $N = 1661$ kHz mm). From (9) we get the relative frequency deviation of measuring transducer (MT):

$$\delta_F(x) = \frac{f(x) - f_0}{f_0} = \frac{0.5mx}{x + a}. \tag{10}$$

Taking into account that $x = x_0 - x_i$ (10) it can be written in such a way

$$\delta_F(x_m) = \frac{0.5m(x_0 - x_m)}{(x_0 + a) - x_m}. \tag{11}$$

Fractional - linear function (9) has such look:

$$\delta_F(x_m) = \frac{a_1(1 + a_2x_m) - a_2(a_0 + a_1x_m)}{(1 + a_2x_m)^2} = \frac{a_0 + a_1x_m}{1 + a_2x_m}, \quad (12)$$

where a_0, a_1, a_2 are the coefficients of approximation of normalized fractional characteristic:

$$a_0 = \frac{0.5mx_0}{x_0 + a}; \quad a_1 = -\frac{0.5m}{x_0 + a}; \quad a_2 = -\frac{1}{x_0 + a}. \quad (13)$$

We can show at PMRT with parameters, which are character to pressure transducer. Let $x_0 = 0.1$ mm, $m = 6.29 \cdot 10^{-3}$, $a = 0.03691$ mm, $x_1 \in [0 \dots 0.06]$ mm. We substitute initial data into (13), find coefficient of approximation of normalized fractional characteristic: $a_0 = 2.297 \cdot 10^{-3}$, $a_1 = -2.297 \cdot 10^{-2}$ 1/mm, $a_2 = -7.304$ 1/mm. Hence:

$$x_m = x_{m\max} = 0.06 \text{ mm}, \quad \delta_F(x_m) = 1.6357 \cdot 10^{-3};$$

$$x_m = \frac{x_{m\max}}{2} = 0.03 \text{ mm}, \quad \delta_F(x_m) = 2.059 \cdot 10^{-3};$$

$$x_m = x_{m\min} = 0 \text{ mm}, \quad \delta_F(x_m) = 22.97 \cdot 10^{-3}.$$

Complete reorganization of output frequency of MT under given parameters of oscillatory system is 22.97 kHz, and $\Delta f = 0$ corresponds own frequency of quartz plate and corresponds $f_0 = 10$ MHz.

For PMRT of micromovings the variable $x \in [0, x_0]$ and normalized graduation characteristic corresponds (10). In accordance with this

$$\delta_F(x) = \frac{a_0 + a_1x}{1 + a_2x}, \quad (14)$$

where $a_0 = 0$, $a_1 = 0.5 \frac{m}{a}$, $a_2 = \frac{1}{a}$.

Having differentiated (14), we get the slope S_F of characteristic PMRT:

$$S_F = \frac{a_1 - a_2a_0}{(1 + a_2x)^2}. \quad (15)$$

We write also the formula for measuring the equivalent dynamic resistance of quartz oscillatory system R_{ekv} under variation of interelectrode gap:

$$R_{\text{ekv}} = R_0 \left(1 + \frac{C_0}{C_{\text{air}}} \right)^2 = R_0 \left(1 + \frac{x \varepsilon_{\text{PE}}}{h_{\text{PE}}} \right)^2 = R_0 \left(1 + \frac{x}{a} \right)^2, \quad (16)$$

where R_0 is a dynamic resistance of under $x = 0$, C_0 is static size of QR, C_{air} the size of air gap.

These parameters are necessary while projecting PMRT, and approximation is essential for the synthesis of linear graduation characteristic (Kolpakov, Pidchenko, Hilchenko, 1999).

5. Accounting for a PRMT electrodes nonparallelity

All given above correlations are received in assumption that electrodes of PMRT are strictly parallel to each other, however it's practically unrealistic. Firstly, it is extremely difficult to provide the parallelism of electrodes while producing PMRT; secondly, the slightest mechanical stress, which appears in the construction under the effect of outer factors can lead to micron defects.

Taking into account everything said before, we take into account nonparallelism, defining the condenser capacity with nonparallel flat electrodes (see Fig. 7) with the radius R of static and $R' > R$ of movable.

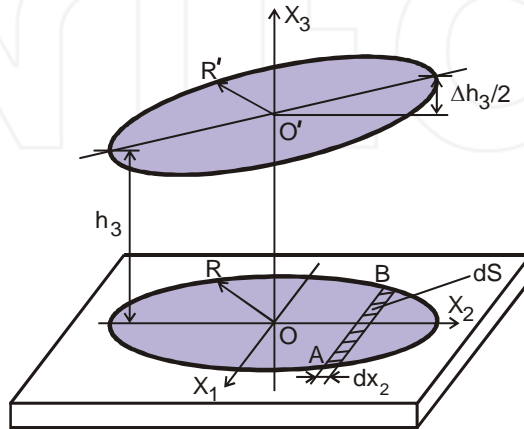

Fig. 7. Record of nonparallelism of PE and flat electrode

The area of the element with the width dx_2 equals

$$dS = AB \cdot dx_2 = 2\sqrt{R^2 - x_2^2} \cdot dx_2 \tag{17}$$

The distance to appropriate element of upper cover equals

$$x_3 = OO' + \frac{\Delta h_3}{2} \cdot \frac{x_2}{R} = h_3 + \frac{\Delta h_3}{2} + \frac{\Delta h_3}{2R} \cdot x_2 \tag{18}$$

Elementary capacity between elementary areas

$$dC = \frac{\epsilon \epsilon_0 2\sqrt{R^2 - x_2^2} \cdot dx_2}{(h_3 + \Delta h_3 / 2) + x_2 \cdot \frac{\Delta h_3}{2R}} \tag{19}$$

whence full capacity of condenser with nonparallel relatively to the axis x_2 electrodes is

$$C = \int_{-R}^R dC = 2\epsilon \epsilon_0 \int_{-R}^R \frac{\sqrt{R^2 - x_2^2} \cdot dx_2}{(h_3 + \frac{\Delta h_3}{2}) + x_2 \frac{\Delta h_3}{2R}} \tag{20}$$

Implementing the transformation of under the integral formula (20), we move from the form

$$\int_{-R}^R dC = S \int_{-R}^R \frac{\sqrt{Z} \cdot dx_2}{p + x_2}, \quad (21)$$

where $Z = a + bx_2^2$; $a = R^2$; $b = -1$; $p = \left(\frac{2}{\delta_h} + 1 \right) R$; $\delta_h = \frac{\Delta h_3}{h_3}$; $S = \frac{4\varepsilon\varepsilon_0 R}{\Delta h_3}$, to the form

$$\int_{-R}^R dC = S \left[b \int_{-R}^R \frac{x_2 dx_2}{\sqrt{Z}} + p \int_{-R}^R \frac{dx_2}{\sqrt{Z}} + (a + bp^2) \int_{-R}^R \frac{dx_2}{(x_2 + p)\sqrt{Z}} \right] \quad (22)$$

Using the table meanings of integrals in (22) and performing some transformations, we get

$$C = \frac{\varepsilon\varepsilon_0 \pi R^2}{h_3 \Phi_{np}}, \quad (23)$$

where $\Phi_{np} = 0.5 + 0.25\delta_{h3} + 0.5\sqrt{1 + \delta_{h3}}$ is the function of nonparallelism; $\delta_{h3} = \frac{\Delta h_3}{h_3}$.

In the terms of graduating characteristic of QR with MIG the relation

$$\frac{C_3}{C_0} = \frac{h_{PE}}{\Phi_{np} \varepsilon_{PE} x} = \frac{a}{\Phi_{np} x}, \quad (24)$$

whence normalized graduating characteristic of PMRT in the conditions of measuring the micromovings

$$\delta_F(x) = \frac{0.5m}{1 + \frac{a}{\Phi_{np} x}} = \frac{0.5m\Phi_{np} x}{\Phi_{np} x + a} = \frac{0.5m\tilde{x}}{\tilde{x} + a}. \quad (25)$$

The analysis for $\Phi_{np} > 1$ and $\delta_{h3} \in [0, 1]$ shows that the display of nonparallelism is equivalent to increasing the gap between mobile and static electrodes in Φ_{npi} times for $\delta_{h3} = \delta_{h3i}$.

In the condition of changing the pressure, the normalized graduating characteristic PMRT under the record of nonparallelism of electrodes has the image

$$\delta_F(x_m) = \frac{\tilde{a}_0 + \tilde{a}_1 x_m}{1 + \tilde{a}_2 x_m}, \quad (26)$$

where $\tilde{a}_0 = \frac{0.5m\Phi_{np}x_0}{\Phi_{np}x_0 + a}$, $\tilde{a}_1 = \frac{-0.5m}{\Phi_{np}x_0 + a}$, $\tilde{a}_2 = \frac{-1}{\Phi_{np}x_0 + a}$.

Hence, the increase of nonparallelism of electrodes (rotation of mobile round the axis X_1) is equivalent to an increase of initial gap x_0 .

Breaking the flatness of two surfaces usually occurs by means of moving of one of it at the same time relative to two axes X_1 и X_2 . That is why in general case the function of nonparallelism can be presented as following

$$\Phi_{np} = \Phi_{np1} + \Phi_{np2}, \quad (27)$$

Where $\Phi_{np1}(\delta_{h31})$ and $\Phi_{np2}(\delta_{h32})$ are partial functions, which allow for rotation of mobile electrode round the axes X_1 и X_2 accordingly. Independence of these rotations define the type Φ_{np1} and Φ_{np2} according to (24).

Therefore, nonparallelism of electrodes of PRMT can be taken into consideration on a stage of its projecting and does not influence linearity of graduating characteristic (Kolpakov, Pidchenko, Taranchuk, et al., 2009).

6. Special features of piezoresonant mechanotrons built on a resonant membrane

Building the measuring force transducers and adduced to it physical quantities (pressure, motion, etc), which use the effect of tensosensitivity QR, is connected with solving complicated problem of connecting force transducers element with quartz piezoelement. Wide possibilities in solving of these tasks are opened while using non- contact frequency control of QR (quartz resonator) by means of modulating the interelectrode gap (Kolpakov, Akulinichev, 1999).

PRMT is shown in Fig. 8 combines the use of two types of control: tensosensitivity of quartz resonator and its control over the modulation of interelectrode gap. Under the activity of applied pressure in the plane of piezoelement, the mechanical strains σ , and as a result of which the PE changes its properties, that is its resonance frequency changes. This is the demonstration of the first control mechanism.

The second control mechanism consists in the following: the resonant membrane, which is jammed on the contour, is under the effect of spread air pressure P . Under the effect of this pressure there happens the PE bending flexure and, as a result, the extension of interelectrode gap x_g , which in its turn leads to the reduction of interelectrode gap capacity C_g . Under the influence of this pressure there is deflection PM and, as

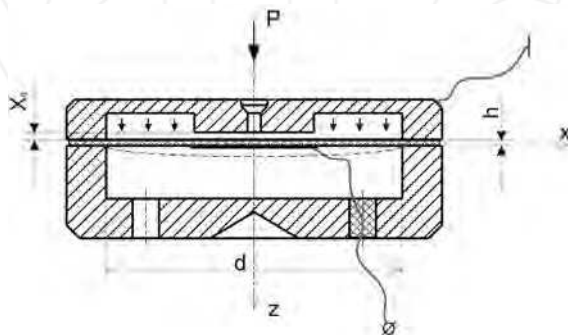

Fig. 8. PRMT structure: h - thickness RM; d - RM contour, free from a jamming

consequence, augmentation of an interelectrode gap that in turn leads to reduction of capacity of an interelectrode gap.

Numerical modeling of tense - strained state RM of round (elliptic) shape, is performed on a basis of the system of engineering analysis ANSYS, which uses the method of finite elements.

Taking into account anisotropic properties of the model the following constants are set: the model of elasticity $E_x = 78 \text{ GPa}$, $E_y = 85.3 \text{ GPa}$, $E_z = 92.6 \text{ GPa}$, coefficient Poisson $\mu = 0.077$ and module of shift $G_{xy} = 42 \text{ GPa}$.

Taking into account the character of loading (the bending flexure is small in comparison with the plate width) and condition $d/h > 10$ we use the model for thin plate. For such model normal to middle plane until the curve remains normal to this plane after curve as well. That is why the deformation of shift is absent, i.e. $\gamma_{xy} = \gamma_{yz} = 0$.

Taking into account geometry and force symmetry of calculated model, it is enough to look at the sector of membrane, which is limited by main axis, with setting the corresponding limited conditions: absence of moving and rotation in plane; plane of symmetry is $xy - u_z = 0$; plane of symmetry $yz - u_x = 0$; $\gamma_{xy} = \gamma_{yz} = 0$. Such assumptions allow to reduce considerably the dimension of being solved task. Jamming the free edge of plate is modeled by means of fixing the junctions, which are situated in the area of jamming, in the plane xy (see Fig. 9).

The plate is loaded with excess pressure $P = 4 \cdot 10^4 \text{ Pa}$ (300 mmHg), which operating in a plane of a cover.

While solving this task the geometrical nonlinearity - the changes of cylindrical rigidity of the cover in the deformation process is taken into account. This is provided by means of regenerating (recalculation) of matrix of rigidity after each iteration. Solving the system of nonlinearity equations is done with the help of the method of Newton-Rawson with automatic change of iteration step.

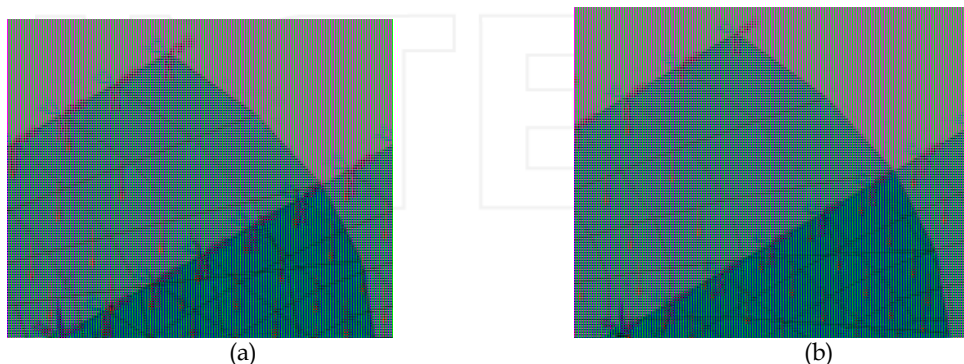

Fig. 9. Finite - element model of RM with visualization of limit conditions and the enclosed pressure: a - round; b - elliptic

As a result of calculations for RM with round cover of jamming and the parameters $h = 169 \mu\text{m}$ and $d = 11 \text{ mm}$ the values of jamming u_z and normal tension σ_x are received, σ_z (see Fig. 10). The calculation of parameters RM with elliptical cover of jamming was done for $a = 5,5 \text{ mm}$ and $b = 4,4 \text{ mm}$ (see Fig. 11).

The analyses of received data in the process of numerous modeling shows, that the value of motion RM for round jamming comprises approximately $20 \mu\text{m}$, elliptic - $13 \mu\text{m}$, and the reserve of solidity on mechanical tensions, penetrating into plane of piezoelement, comprises 5.5.

The results of modeling showed high effectiveness of proposed methods on the basis of method of finite elements for performing high - precise calculations of complicated constructive elements of piezoquartz measuring transducers on the stage of their projecting and exploitation, making analytical decision for which is impossible.

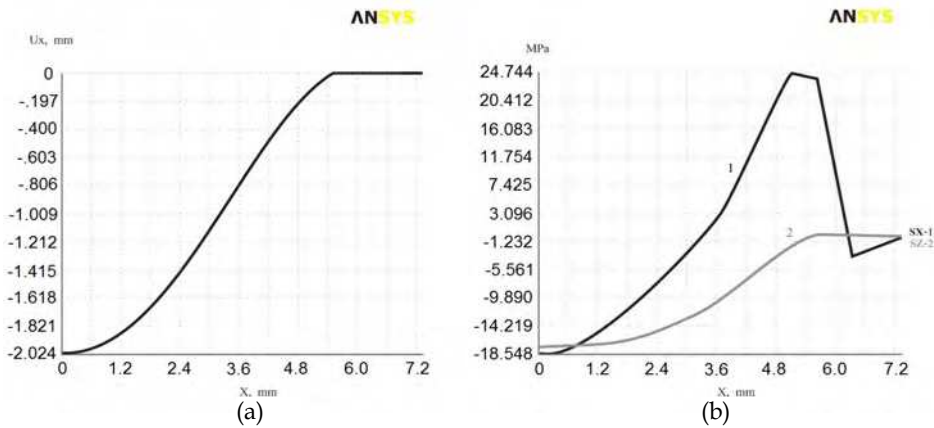

Fig. 10. Calculations of parameters of round RM: (a) bending flexure; (b) tension σ_x (1) and σ_z (2)

7. Analyses of a piezoresonant mechanotron temperature characteristics employing modulated interelectrode gap

In accordance with (12) and (14) temperature sensitivity of QR with MIG is determined by the variations $x_0(T)$, $m(T)$, $\epsilon_{PE}(T)$, $h_{PE}(T)$. Let us look at factors more detailed, which contribute into the changes of information frequency parameter.

Permittivity of quartz depends very little on orientation of plates, its capacity temperature coefficient (TC) under increasing the temperature to 100°C is little and in general it determines the character of temperature dependence $C_0(T)$ ($TC\epsilon_{PE} = 5 \cdot 10^{-5} / ^\circ\text{C} \pm 25\%$). Temperature coefficient C_0 :

$$TCC_0 = C_{0(20^\circ)} \left[1 + 5 \cdot 10^{-5} (t^\circ - 20^\circ) \right]. \tag{28}$$

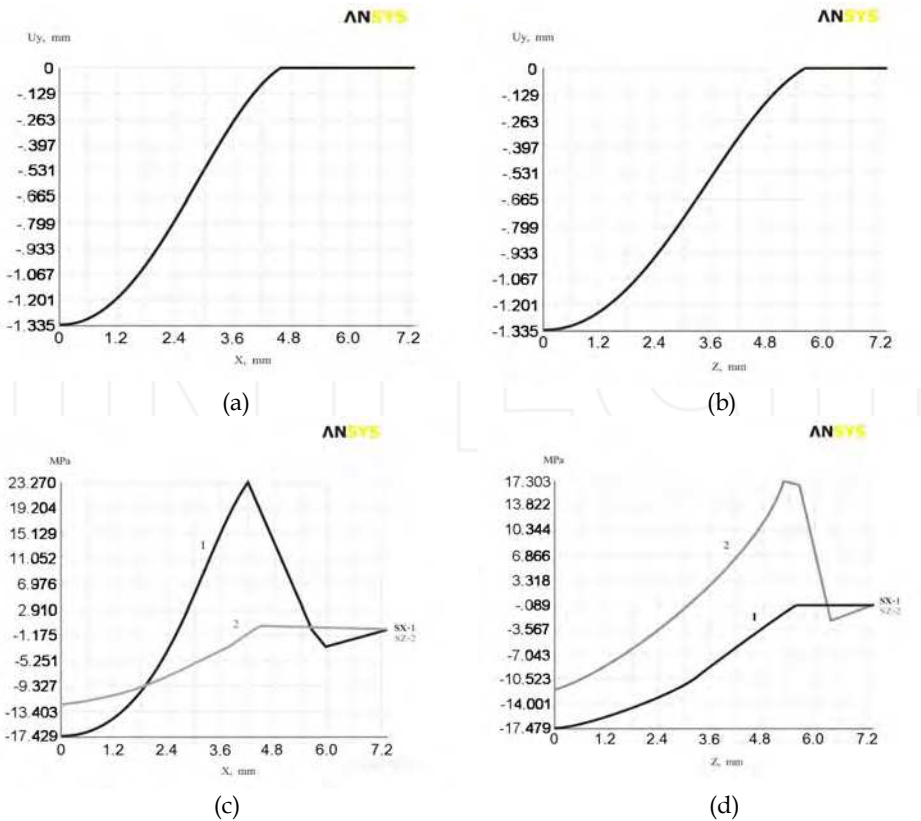

Fig. 11. Calculated parameters of elliptic RM: (a), (b) - bending flexure of membrane on axis a and b of ellipse accordingly; (c), (d) - tension σ_x (1) and σ_z (2) - on axis a and b of the ellipse accordingly

Temperature dependence of dynamic capacity $C_q(T)$ for flat PE AT-cut:

$$TCC_q = C_{q(20^\circ)} \left[1 + 2.5 \cdot 10^{-4} (t^\circ - 20^\circ) + 2 \cdot 10^{-7} (t^\circ - 20^\circ)^2 \right]. \tag{29}$$

For the wide temperature interval (-60...+100)°C quadratic terms can not be taken into account. Temperature dependence $h_{PE}(T)$ is estimated by the value of temperature coefficient of linear expansion (TCLE = $10^{-5} \text{cm} / ^\circ\text{C}$). Dependability $x_0(T)$ is defined by TCLE of metal envelope, glued material, difference of TCLE frame and regulated screw, thermal deformations of mobile electrode (membrane). In accordance with (12), taking into account said before,

$$\delta_{1f}(T) = \frac{a_{0(T)} + a_{1(T)}(\Delta T \alpha_x + x_0)}{1 + a_{2(T)}(\Delta T \alpha_x + x_0)}, \tag{30}$$

where $a_{0(T)} = a_0 \frac{1 + \delta_m + \delta_{x_0}}{(1 + \delta_{x_0a})}$, $a_{1(T)} = -a_0 \frac{1 + \delta_m + \delta_{x_0}}{(1 + \delta_{x_0})(1 + \delta_{x_0a})}$; $a_{2(T)} = \frac{a_{1(T)}}{0.5m(1 + \delta_m)}$.

It is known that detuning of relative frequency of successive resonance leads to a turn of the temperature frequency characteristic (TFC) QR. Dependence of TFC on detuning depends on the change of capacitive relation of resonator in the temperature interval and is calculated

$$\delta_{i_{mcrp}} = 0.5m\alpha_m e_y (T - T_0), \tag{31}$$

where α_m is the temperature coefficient of capacitive relation (for resonators AT-cut $\alpha_m \approx 3 \cdot 10^{-4}$, e_y - is relative detuning as to the frequency of successive resonance of QR with MIG when $x=0$, T - is current value of temperature, T_0 - temperature, relative to which the change TFC is defined. Therefore, the relative change of frequency

$$\delta_{2f}(T) = \frac{a_{0(T)} + a_{1(T)}x_0}{1 + a_{2(T)}x_0} \alpha_m \Delta T. \tag{32}$$

The influence of temperature warp of electrodes and changes x_{0ecv} are taken into account by introducing the correction to the value of initial gap:

$$\delta_{3f}(T) = \frac{a_{0(T)} + a_{1(T)}(x_0 + \Delta x)}{1 + a_{2(T)}(x_0 + \Delta x)}. \tag{33}$$

It is necessary to take into account the changes of frequency, which are connected with temperature instability of oscillator, piezoelement and occurred, because of temperature changes of construction element size, strain load of PE. Therefore

$$\delta_{4f}(T) = \delta_{fget}(T) + \delta_{fa}(T) + K_F \Delta T. \tag{34}$$

Taking into account all said above, we write approximate model of thermal- sensitivity of measuring transducers with QR MIG:

$$\begin{aligned} \delta_f(T) = & \delta_{1f}(T) + \delta_{2f}(T) + \delta_{3f}(T) + \delta_{4f}(T) = \frac{a_0(T) + a_1(T)(\Delta T \alpha_x + x_0)}{1 + a_2(T)(\Delta T \alpha_x + x_0)} + \frac{a_0(T) + a_1(T)x_0}{1 + a_2(T)x_0} \alpha_m \Delta T + \\ & + \frac{a_{0(T)} + a_{1(T)}(x_0 + \Delta x_0)}{1 + a_{2(T)}(x_0 + \Delta x_0)} + \delta_{fget}(T) + \delta_{fa}(T) + K_F \Delta T. \end{aligned} \tag{35}$$

Having grouped the components, we get

$$\delta_f(T) = \frac{a_{0(T)} + a_{1(T)}(x_0 + \alpha_x \Delta T + \Delta x_0)}{1 + a_{2(T)}(x_0 + \alpha_x \Delta T + \Delta x_0)} (1 + \alpha_m \Delta T) + \alpha_{fget}(T) + \delta_{fa}(T) + K_F \Delta T. \tag{36}$$

Dependence of frequency of QR on the temperature is defined as physical properties of crystal element, as well as the size and material of its electrodes, quartz holders, the topology of fastening of a piezoplate. At fast changes of temperature (temperature blow) the

main reason of instability of frequency is the presence of temperature gradients in quartz PE and mechanic tension, which appears in the space of piezocrystal, as well as in the place of electrodes placement and fastening of quartz holders under not uniform resonator heating (Kolpakov, Pidchenko, Taranchuk, et al., 2009).

Let's survey geometrical model of node of the quartz holder – piezoresonator. Researched construction (see Fig. 12) usually consists of two parts: quartz piezoplate (1) and quartz holder (2), which is produced of duraluminium DT-16.

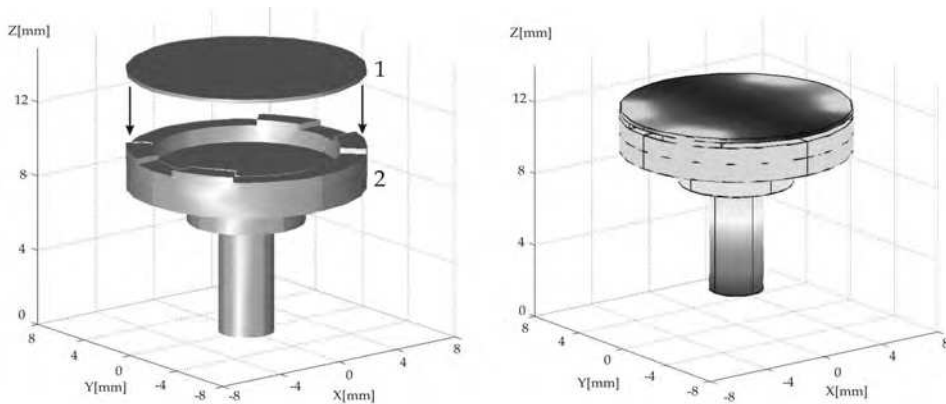

Fig. 12. The construction of a node of quartz holder of piezoresonant sensor with MIG

Solving the equation of term heat conductivity

$$\rho C \frac{\partial T}{\partial t} - \nabla \cdot (k \nabla T) = Q, \quad (37)$$

where ρ is density, C is heat capacity, k is coefficient of heat conductivity, Q is the meaning of heat source, by the method of finite elements in the system of mathematical modeling MATLAB (FEMLAB) under abrupt changes of temperature from 0°C to 50°C (limit conditions of third type) we get the distribution of temperature field of sensor PE in character time moments (see Fig. 13) We use received information for calculating instability of PRMT frequency.

For definition of the temperature induced shifts of frequency piezoelectric resonator we will present the general shift of frequency in a kind

$$\frac{\Delta f}{f_0} = \left(\frac{\Delta f(T)}{f_0} \right)_{\text{stat}} + \left(\frac{\Delta f(T_R(\psi) - T_0)}{f_0} \right)_{\text{dyn}}, \quad (38)$$

where $\left(\frac{\Delta f(T)}{f_0} \right)_{\text{stat}} = \sum_{i=1}^3 a_i (T - T_H)^i \Big|_{T=T_{\text{PE}_{\min}}}$ is static component of instability of PE, which is

defined by its static temperature- frequency characters and minimal temperature $T_{\text{PE}_{\min}}$;

$\left(\frac{\Delta f(T_0 - T_R(\psi))}{f_0}\right)_{\text{dyn}}$ - is dynamic component of instability, which originates by means of distortion of temperature field of PE.

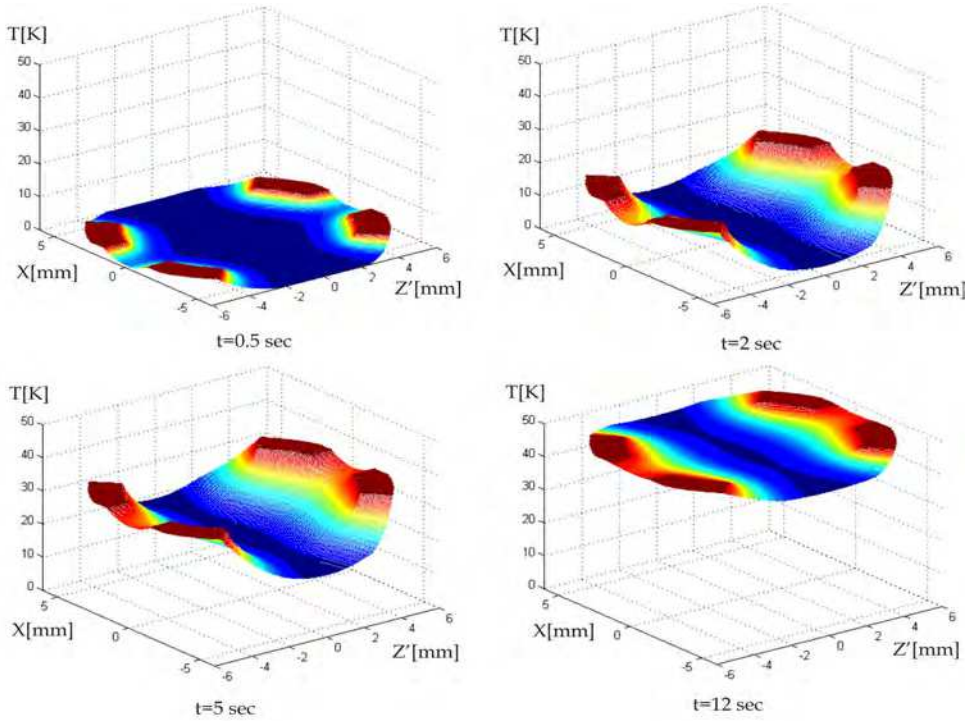

Fig. 13. Distribution of temperature field in character time moments

Static (quasi - static) thermal behavior of PE with enough accuracy is defined by the polynomial of third degree. For defining the dynamic component of instability of frequency we use the methods, which are described in (Taranchuk, Pidchenko, 2002 - 2005). The relative shift of personal frequency of piezoplate fluctuations under the effect of external force $F(\psi)$ applied onto the piezoelement ends of disc shape along its diameter, is calculated as

$$\frac{\Delta f}{f_0} = \frac{f_0}{2R \cdot n} \cdot K_f(\psi) \cdot \Delta F(\psi), \quad (39)$$

where ψ - is the azimuth of force applying $F(\psi)$; f_0 - is the minimal fluctuations frequency; n - is the number of mechanical harmonica; R is the radius of PE; $K_f(\psi)$ is force - frequency coefficient of Rataiskiy.

To find $\Delta F(\psi)$ we take into account the fact, that tensor of elastic deformations of elementary volume of piezoplate is bound with changes of temperature ΔT by a parity $r_{ij} = l_{ij} \cdot \Delta T$, where l_{ij} are the components of tensor of second rank of quartz thermal expansion, and force tension, which originate in this are depicted by generalized law of Gook $t_{ij} = C_{ijkl} \cdot r_{kl} = d_{ij} \cdot \Delta T$, where C_{ijkl} are the components of the tensor of the forth rank of modules of frequency (Cady, 1946).

Realizing the transition $\mathbf{d}' = \Gamma \mathbf{d} \Gamma^{-1}$ into the plane of piezoplates of the most prevailing one-rotary AT ($yx1/\beta^\circ$) and two- rotary SC, FC ($yxbl/\gamma^\circ/\beta^\circ$) - the cuts of piezoelements and using with a glance of geometric peculiarities of PE the cylindrical coordinate system, we get:

$$\Delta F_r(\psi) = d_{rr}(\psi) \cdot S_e \cdot \Delta T_r(\psi), \quad (40)$$

where $\Delta F_r(\psi)$ are changes of allocated forces, which act in the volume of piezoplate along the radius r ; $S_e = R \cdot h \cdot \Delta \psi_e$ is the area of an elementary platform of a face surface of PE, h is the thickness of PE.

Taking into account (40) in parity (39) and carrying out integration on Ψ in the limits from 0 to π and on r in the limits form 0 to R we come to integral from of writing

$$\frac{\Delta f}{f_0} = \frac{f_0}{2n} \cdot h \int_0^\pi K_f(\psi) \cdot d_{rr}(\psi) [T_R(\psi) - T_0] d\psi, \quad (41)$$

where $T_0 = \frac{1}{h} \int_0^h T_0(h) dh$, $T_R(\psi) = \frac{1}{h} \int_0^h T_R(h, \psi) dh$ - average in the volume temperature in the centre and on the edge of PE.

Received on the basis (44), dynamic components of instability of frequency for two types of quartz - holders are demonstrated on Fig. 14, (a), where curve 1- is the dynamic instability of frequency of quartz holder with four points of fastening of PE (see Fig. 12), curve 2 - for quartz holder with thermal contact on the contour of PE. It can be seed, that in second case there are big deformations of temperature area of PE, which cause therefore much bigger instability of frequency (approximately order).

On Fig. 14, (b) there are settlement (in accordance with (38)) and experimental curves of general shift of frequency of sensor under the thermal effect (from 50°C to 0°C). Good coincidence of curve data proves the adequacy of used mathematical model, which can be used for further research.

The construction of quartz holder influences greatly the general shifts of frequency of PE PRMT. Under this there appear considerable temperature gradients and mechanical tension in piezoplate, which lead to substantial increase of dynamic component of instability. Its maximum values can exceed the frequency shifts, which are caused by quazi-static temperature frequency characteristics (TFC). That is why the construction of PRMT must be optimized with a glance of thermal processes, which take place in quartz holder and piezoelement (Taranchuk, Pidchenko, 2002 - 2005).

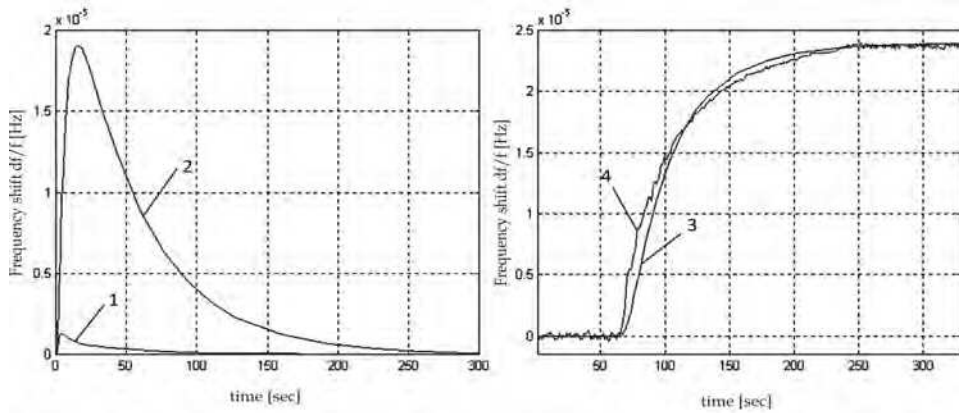

Fig. 14. Dynamic component (a) and frequency shift of piezoelectric resonator (b): curve 1 - is the dynamic instability of frequency of quartz holder with four points of fastening of PE; curve 2 - for quartz holder with thermal contact on the contour of PE; 3 - settlement curve; 4 - experimental curve

8. Implementation of piezoresonant mechanotrons employing modulated interelectrode gap and development research

On the basis of research, the results of which are presented above, the authors worked out the number of sensors of excessive pressure for medical appliances.

On Fig. 15 the PMRT of pressure is presented, in which for modulation of inter electrode gap the metal membrane is used. The case 1 made of polystyrene is connected with metal basis 2. Between top groove of base 2 and union node 11 there is seal ring 12. In a ground part of the basis 2 the node quartz holder 6 which is rigidly bridged by means of a rivet 4 to an elastic element 5 is established. On a working surface quartz holder 6 the flat disk piezoelement 3 AT - cut with the round electrode bridged electrically with a potential conclusion of the sensor 7 is established.

Elastic element 5 through the sealing ring 8, and also the membrane 10 are jammed on a contour by means of a clamping node 11. All nodes of PMRT have hard fixing and do not need applying welding operations for junctions. The size of initial gap between quartz piezoelement 3 and membrane 10 is provided with changes of the flexure of elastic element 5 with the help of screw 9.

In the condition of absence, towards atmosphere, air pressure in the cuff, which is connected by the tube to the nipple part of frame 1, the deformation of membrane 10 is absent, as inner volume of basis 2 is not pressurized and the pressure onto the membrane from both sides is identical. In such condition quartz resonator, which is formed by piezoelement 3, metal membrane 10 and switched into the scheme auto generator PRMT is stimulated on the frequency which corresponds zero excessive pressure. When pressure available exceeds the atmosphere one, the membrane 10 is bended, the gap capacity between unused surface of piezoelement 3 and the surface of central part of membrane goes down: it leads to decreasing the resonance frequency of QR with variable gap (Kolpakov, Pidchenko, Hilchenko, 1998).

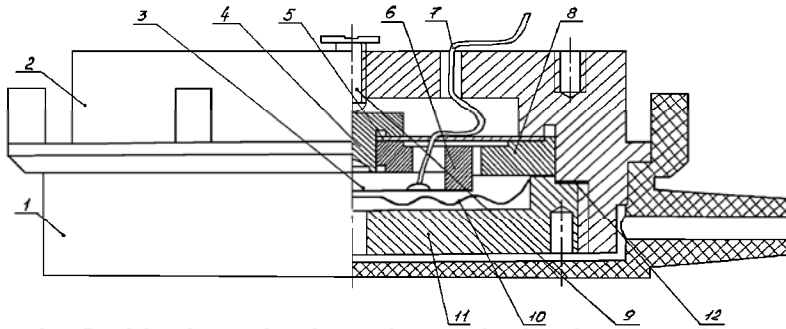

Fig. 15. Construction of PMRT with metal membrane

The basic advantage of this PRMT is complete absence of hysteresis effects, which are inherent in sensors with direct influence onto piezoelement, which substantially increases the reproducibility of graduating characteristics and, as a result, accuracy of measurements.

Typical value of permitted ability of given PRMT with metal membrane comprises 0.05...0.08 mmHg, and main error does not exceed 0.1...0.15%. Highly effective appliance of PMRT with capacity pneumatic control is its use in measuring transducer of pulse air pressure of sphygmographic research (Taranchuk, Pidchenko, et al., 2010).

Pneumatic scheme of PMRT is show Fig. 16, (a) has two channels: K1, which has pneumatic the filter of the bottom frequencies, which consists of pneumatic resistance of filter R_f , pneumatic throttle R_{tr} and under membrane capacity V_{K1} ; K2 - is direct channel of action onto membrane. Resulting influence of two channels onto the movement of membrane is equivalent to the operation on given pressure $P = P_- + P_0$ to the pneumatic filter of the top frequencies. Here P_0 - in constant (slowly changeable) and P_- - variable (informative) component of pressure.

The frequency of cut PRMT is defined by the formula

$$f_{cut} = \frac{1}{2\pi R_{\Sigma} C_{FC}}, \quad (42)$$

Where $C_{FC} = \frac{V_{K1}}{\mathfrak{R}T}$ is pneumatic capacity of the filtrational chamber V_{K1} ; $R_{\Sigma} = R_f + R_{tr}$ is total pneumatic resistance; $V_{K1} = \pi D_{FC}^2 h_{FC} / 4$, D_{FC} and h_{FC} - the volume, height and diameter of filtrational chamber accordingly; $\mathfrak{R} = 287 \frac{Дж}{кг \cdot К}$ is gas constant; T - is the gas temperature (air temperature).

Resistance of cloth filter is defined as

$$R_F = \frac{\Delta P_F}{\nu \cdot S}, \quad (43)$$

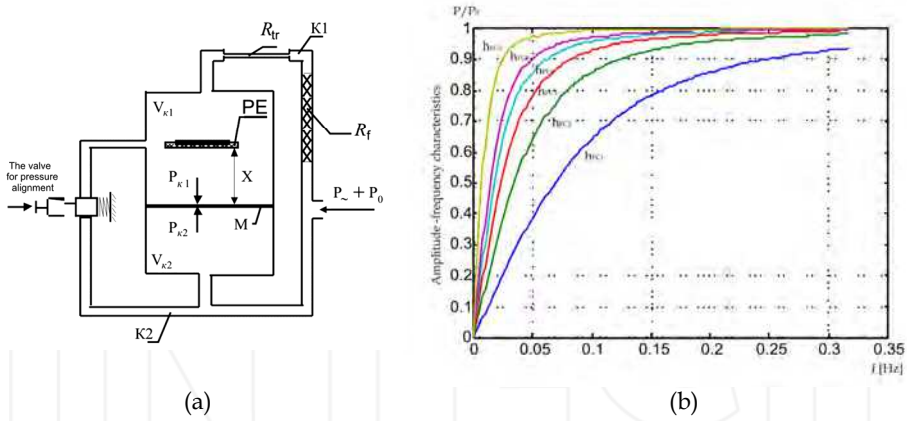

Fig. 16. (a) Pneumatic scheme of PRMT; (b) The amplitude- frequency characteristics of sensor of pressure for values $l_{tr} = 1 \text{ mm}$

where ΔP_F is pressure drop on cloth filter; ν - speed of air flow through filter; $S = \pi d_F^2 / 4$ - the area of cross- section of cloth filter opening, d_F is diameter of opening of cloth filter. For the material for cloth filter, type felt: $\Delta P_F = 49 \text{ Pa}$, $\nu = 0.02 \text{ m/min}$ and for $d_F = 1.5 \text{ mm}$ - $R_F = 8.32 \cdot 10^{10} \text{ Pa} \cdot \text{sec} / \text{m}^3$.

Resistance of throttle equals

$$R_{tr} = \frac{128\eta l_{tr}}{\pi d_{tr}^4 \rho}, \tag{44}$$

where l_{tr} , d_{tr} are the length and diameter of throttle; ρ - the density of air under normal conditions, $\rho = 1.205 \text{ kg} / \text{m}^3$; $\eta = A + B \cdot T$ is dynamic coefficient of gases viscosity; A, B are constant coefficients (for air $A = 37.4 \times 10^{-7} \text{ Pa} \cdot \text{sec}$, $B = 0.506 \times 10^{-7} \text{ Pa} \cdot \text{sec}$). In normal conditions ($T = 293\text{K}$) the dynamic coefficient of air viscosity $\eta = 0.186 \times 10^{-4} \text{ Pa} \cdot \text{sec}$.

The cut frequency of PRMT is defined by the spectrum of sphygmograph signals - (0.036...60) Hz and comprises approximately $f_{cut} \approx 0.03 \text{ Hz}$. Having based on chosen cut frequency, taking into account real size $D_{FC} = 40 \text{ mm}$ and received cloth filter $R_F = 8.32 \cdot 10^{10} \text{ Pa} \cdot \text{sec} / \text{m}^3$, we let's define in conformity with (42) - (44) the constructional parameters of throttle (diameter d_{tr} and the length l_{tr}) and the height of filter chamber h_{FC} (see Table 1, Table 2 and Fig. 16). Analyses of received data shows that substantial influence onto the cut frequency f_{cut} makes the height of filter chamber h_{FC} (see Table 1, Table 2). For $d_{tr} \leq 0.1 \text{ mm}$ the resistance of throttle R_{tr} considerably depends on l_{tr} and should be taken into account while calculating PRMT (Fig. 16, (b)), for $d_{tr} = (0.2...1) \text{ mm}$ and $l_{tr} = (1...10) \text{ mm}$ the throttle resistance R_{tr} is much smaller that the resistance of cloth filter $R_f \gg R_{tr}$ and can not be taken into account while calculating total resistance R_{Σ} . In such case parameters PRMT are defined as usual by the height of filter camera h_{FC} (see Table 2).

$h_{FC}, \text{ mm}$	$f_{cut}, \text{ Hz}$			
	$l_{tr}, \text{ mm under } d_{tr} = 0.1 \text{ mm}$			
	1	2,5	5	10
1	0,11	0.107	0.093	0.073
2	0.0595	0.0539	0.0465	0.0365
3	0.0397	0.0359	0.031	0.0243
4	0.0298	0.0269	0.0232	0.0182
5	0.0238	0.0215	0.0186	0.0146
10	0.0119	0.0108	0.0093	0.0073

Table 1. Choosing the geometry sizes of elements of PRMT

$h_{FC}, \text{ mm}$	1	2	3	4	5	10
$f_{cut}, \text{ Hz}$	0.128	0.064	0.0427	0.032	0.0256	0.0127

Table 2. Choosing the height of filter chamber while $d_{tr} = (0.2...1) \text{ mm}$ and $l_{tr} = (1...10) \text{ mm}$

Thus, proposed construction PRMT with successive connection R_f and R_{tr} allows to vary the parameters of throttle in accordance with technological possibilities of production and to realize it without applying special capillary technology (Kolpakov, Dobrova, et al., 1999; Pidchenko, Taranchuk, et al., 2002).

The advantage of given construction of PMRT is in following: the capacity of interelectrode gap is defined only by the amplitude of pulse wave of blood pressure and technological tolerance of membrane mounting, and additional errors of nonparallelism of membrane and PE are excepted by means of removal of: quazi - static component of air pressure. This allows to increase the allowing ability of measuring transformer for sphygmographic research on basis of PMRT while measuring dynamic air pressure in more than three-five times as compared with known devices.

On Fig. 17 it is presented the third type of frequency PMRT of pressure with the use of resonant membrane (RM), which is developed in paragraph 6 of given chapter.

PMRT with PM works as follows. Under the absence of excessive as to atmosphere pressure of air in the chamber, which is limited by piezoelement 5 and inside surface of cover 1, the deformation of piezoelement 5, which plays the role of resonating membrane, does not happen. Quartz resonator, connected in the scheme of oscillator PRMT is stimulated on the frequency, which corresponds zero excessive pressure. From the exit of oscillator the information signal is taken, the frequency of which f_0 corresponds the beginning of modulation characteristic of PMRT. Under the pressure in the pressure chamber, which exceeds the atmosphere pressure, there happens the small bending flexure of piezoelement 5, as a result the size of a gap between the free surface of piezoelement and the surface of cylindrical bump would increase, which leads to increasing the frequency $f(P)$. In given PRMT two mechanisms of controlled of frequency of the quartz resonator take place. Capacitor controlled, at the expense of change of size of a gap between a free surface of a piezoelement and a surface of a cylindrical ledge 6, and controlled on the basis of effect tensosensitivity:

$$\Delta_{\Sigma}(p) = \Delta_C(p) + \Delta_{\sigma}(p); \tag{45}$$

$$K_f^f = \frac{\partial f}{f_0 \cdot \partial P} = \frac{N}{2} \int_0^{\pi} K_f(\psi) d\psi, \tag{46}$$

where N is frequency constant; K_f is the coefficient of Rataiskiy; ψ is azimuth of load; f_0 is personal resonance frequency of piezoelement ($f_0 = 10\text{MHz}$); P is applied spread pressure.

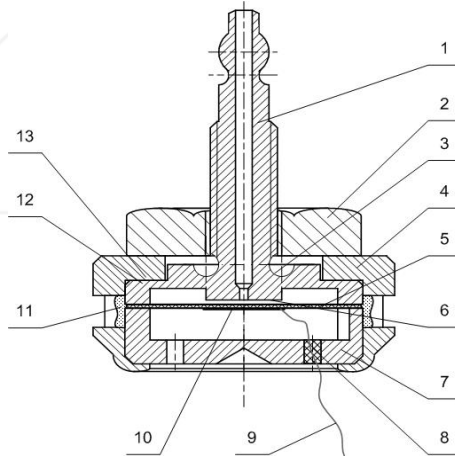

Fig. 17. Construction of pressure sensor with PM:
 1- cover; 2 - regulating nut; 3 - annular groove; 4 -ring; 5 - piezoelement; 6 - cylindrical ledge; 7 - basis; 8 - compactor; 9 - potential lead; 10 - mobile electrode; 11- hermetic; 12 - samples; 13 - basis ledge; 14 - groove; 15 - two pairs of diameter - opposite basis ledge

Experimental researches were held for PMRT with PM with PE of diameter 14 mm and electrode diameter 4 mm under $P \in [0, 300]$ mmHg. Static modulation characteristic of PMRT with PM (see Fig. 18) includes demonstration of both mechanisms of changes the

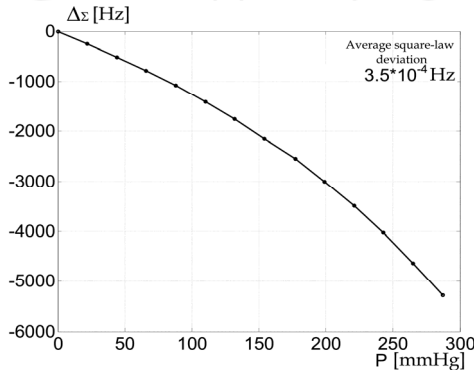

Fig. 18. Summarized modulation characteristic for PMRT with PM

resonance frequency. For estimating the impact of the mechanism of tensosensitivity a separate experiment was held, in which PM of the same size contained two electrodes. Thanks to this the capacity mechanism of frequency was excluded. The analysis of tensosensitivity of mechanisms (see Fig. 19) shows that impact of tensosensitivity of component $\Delta\sigma$ comprises (2.5...3.5)%. Therefore, the use of model, which takes into account only capacity mechanism of control, for PMRT with PM brings the error, which does not exceed 3.5 %.

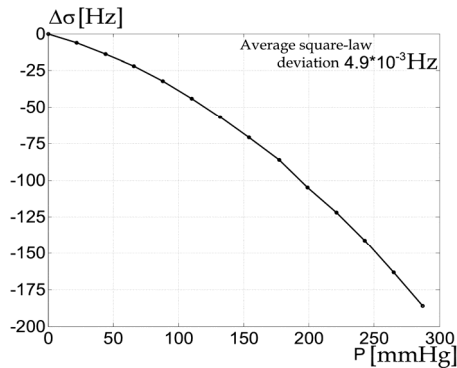

Fig. 19. Tensosensitivity modulation characteristic for PMRT with PM

The temperature error of proposed PMRT is substantially decreased thanks to two peculiarities of its construction.

Firstly, surfaces of a piezoelement and the metal surfaces jamming it, have small roughnesses, therefore the forces of a friction arising because of difference of temperature of Rataiskiy equals zero (see Fig. 20).

This means that in ideal case this component of temperature error equals zero, and practically it is very little.

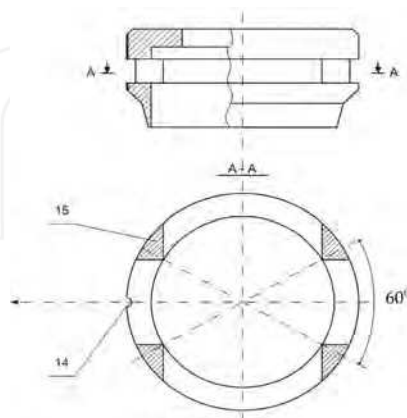

Fig. 20. The construct of quartz holder

The increase of deviation of frequency MC in one and half times can be achieved by increasing the diameter of PE. The results of experimental researches of PMRT with PM $\varnothing 18$ mm is demonstrated in Fig. 21. As for PMRT with disc flat PE of AT-cut with the diameter 18 mm, the diameter of electrode is 8 mm and thickness $h_{PE} = 169 \mu\text{m}$ which corresponds nominal frequency $f_0 = 10$ MHz, while applying the pressure from 0 to 300 mmHg, the maximal value of banding flexure of piezoelement in order less than its thickness and comprises $16.23 \mu\text{m}$. Elements and construction of PMRT with PM are demonstrated in Fig. 22.

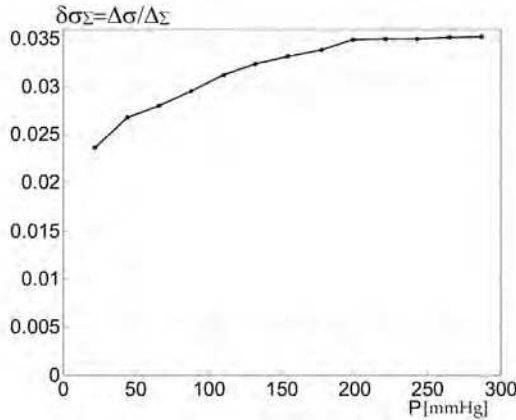

Fig. 21. The relative characteristic of sensitivity



Fig. 22. Elements and construction of PRMT with PM

Typical technical characteristics of sensor of pressure on basis of PMRT with PM:

- Resolution in the range of applied pressure $P \in [0, 300]$:
 - for small pressure, less than 10 mmHg.....0.008 - 0.01 mmHg;
 - for maximum pressure not worse.....0.025 mmHg.
- Full change-over of frequency, not less than9.5 kHz.
- The value of hysteresis after maximum load, not more than2 Hz;
- Basic error of measurement the surplus pressure, not more than.....0,15%.

Coefficients of approximation of characteristic of transformer of PMRT, calculated in accordance with (13) form: $a_0 = 1938.87\text{Hz}$, $a_1 = 63.95\text{Hz} / \text{mmHg}$ $a_1 = 0.002308 \text{ 1} / \text{mmHg}$

Advantages of this type of PMRT with resonant membrane are the exception of effects, which are connected with nonparallelism of membrane and piezoelement, considerable decrease of temperature errors, connected with construct of quartz - holder, simplification of construct of sensor (Pidchenko, Taranchuk, et al., 2003).

9. Application of piezoresonant mechanotrons of surplus air pressure in medical sphygmographic systems to register pulse variation of cardiovascular human system

On the basis piezoresonant mechanotrons of surplus air pressure the authors developed medical automated multichannel sphygmographic system "BIOTON". This system allows to do computer diagnostics of parameters of human hemodynamics, the registration of local and volume sphygmogrammes for solving the tasks of polycardiography and poly sphygmography. System "BIOTON" differs from the existing POLISPECTR-PWV (Russia), Arteriograph "TensioClinic" (Hungary), Complior (France) by its improving informativeness and quality of reproduction of pulse fluctuations.

Sphygmographic system (see Fig. 23) consists of sensors of pulse oscillation on a basis of PMRT (Sensor 1-n) and the block of microcontroller (MCU). After primary information processing it is transferred into computer on standard interface USB 1.1/2.0.

Each sensor contains measuring transducer of pressure on a base of PMRT, connected into oscillatory system of oscillator. Change of interelectrode gap ПPMT 1...n under the influence of pressure in a receiver funnel pulse oscillations leads to frequency change on an Oscillator 1...n exit. Further the signal arrives on Frequency multipliers 1...n for increase in information deviation of frequency. On each channel it is realized the method of linearization of graduating characteristics of sensors, for which Synthesizer of direct synthesis (DDS AD 9959) is used, which allows to give the optimal frequency of heterodyning in each channel with the accuracy of less than Hz. From the exit of Mixer 1...n signal of differential frequency comes onto Microcontroller ADUC841, which is used in the regime of period measuring.

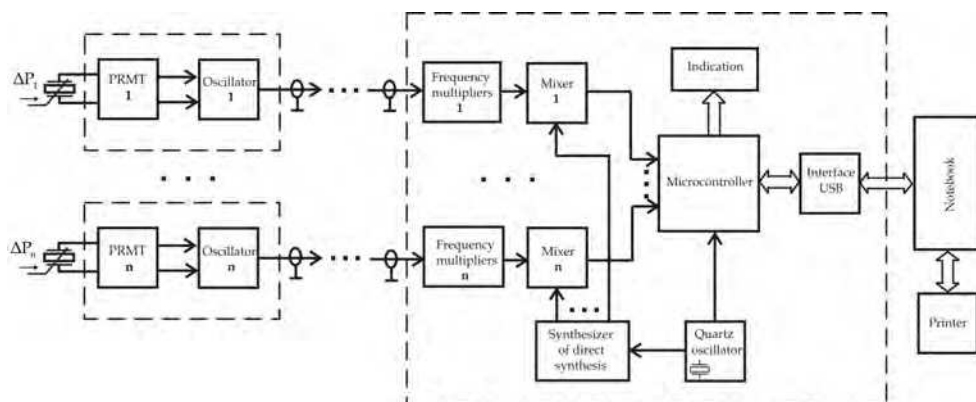

Fig. 23. Structure of sphygmographic system BIOTON

For an exception of additional errors the uniform quartz generator of clock frequency for DDS and MCU is used. Received data in real time are given to standard IBM compatible personal computer (Notebook), which is the part of the system. Further processing is done with the help of worked out special software, which functions under control of OS Windows 2000/XP/Vista/7. The developed software allows to carry out the semi-automatic analysis and data processing, recording of results and creation of databases for research of hemodynamics of cardiovascular system of patients. Possibility contour-time (with allocation of characteristic points) and the spectral analysis sphygmographic curves (see Fig. 24), definitions of an index of augmentation AI_x and speeds of distribution pulse waves (PWV) (see Fig. 25), and also allocation of the most typical sites sphygmograms, comparisons two or several pulse oscillation is provided. For elimination of influence of artifacts procedures of a digital filtration and smoothing are used (Taranchuk, Pidchenko, 2008 - 2010).

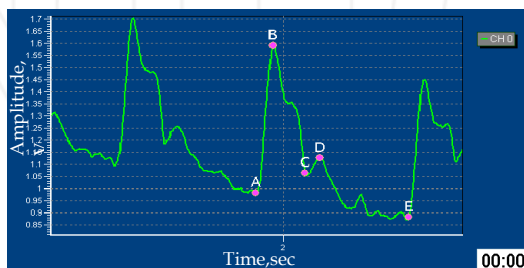

Fig. 24. Contour - time analysis of sphygmogram

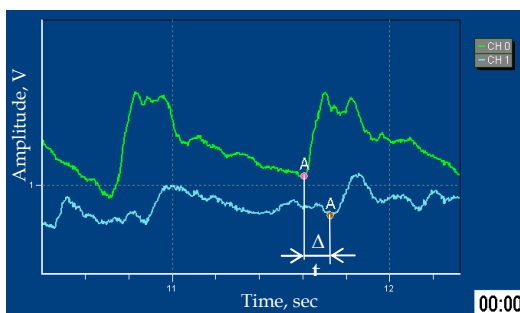

Fig. 25. Defining PWV by signals on carotid artery and femoral artery

System BIOTON is highly effective while definition variability of heart rhythm (VHR) on basis of measured sphygmograph curves of carotid artery during certain time (not less than five minutes). Developed software allows to do statistic, correlation, spectral analysis and form the estimation of analysis results of VHR while doing functional tests (see Fig. 26).

System "BIOTON" is designed for applying in following medicine areas:

1. Cardiology (non- invasive monitoring of hemodynamics, scientific research).
2. Family medicine (primary examination, early diagnosis of atherosclerosis).
3. Nephrology (beginning and progressing of atherosclerosis because of problems with kidneys).
4. Diabetes study (faster process of aging of vessels because of increasing sugar in blood).

5. Obstetrics and gynecology (preeclampsia - endothelial illness, menopause - main factor of risk of atherosclerosis);
6. Children cardiology (often atherosclerosis appears in early age).

Constructive realization of the block of the microcontroller and sensor of surplus pressure on the basis of PRMT are in show Fig. 27.

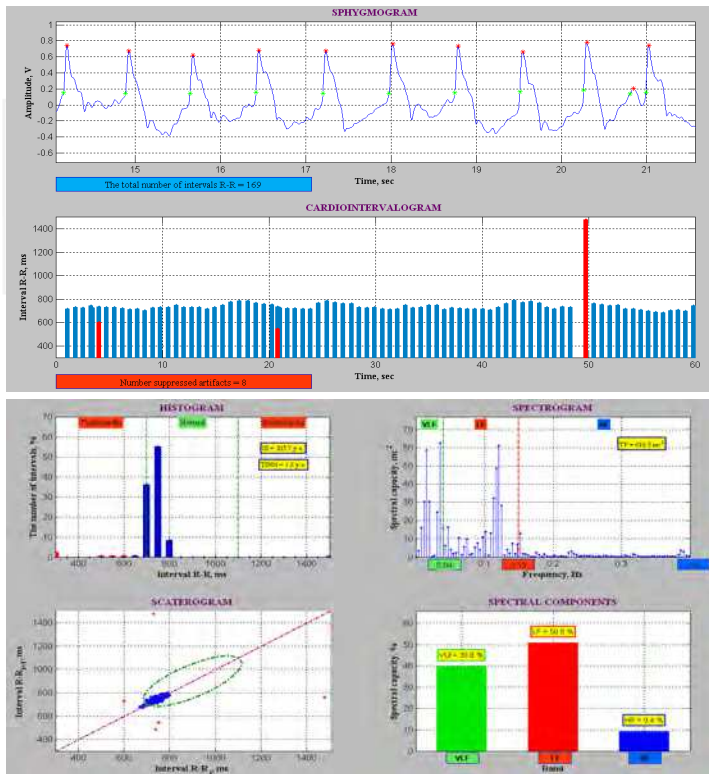

Fig. 26. Results of measurements variability of heart rhythm

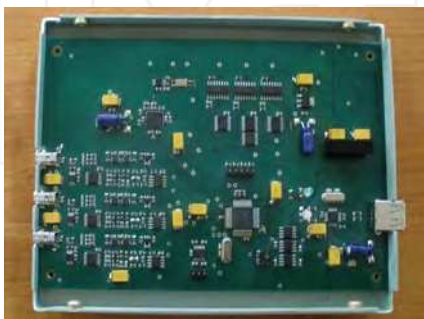

Fig. 27. Constructive realization of the block of the microcontroller and sensor of surplus pressure on the basis of PRMT

10. Conclusion

The result of scientific research presented in present chapter is the creation of new element, named piezoresonance mechanotron, which can be used as basic for constructing wide range of highly informative measuring and diagnostic devices and systems. In combination with linearizer of graduating characteristics, which realize approximation approach, presented constructions of PMRT provide precision measurement of dynamic as well as static pressure on the level of the best world models. They can be used for modernization of existing as well as in the designing the perspective biomedical systems. Wide functional possibilities of PMRT allow, by means of slight changes of its construction, to measure wide range of parameters, such as travel, pressure, acceleration, mass, temperature and others, which lead to micromoving of physical magnitudes. The construct of PMRT permits its realization in microminiature variant on basis of micromembrane element, formed by means of MEMS technology.

11. References

- Cady W. (1946). *Piezoelectricity*, New York and London: McGraw-Hill.
- Kolpakov F., Pidchenko S., Hilchenko G. (1997). "Pressure Sensor", Patent Russia № 2098783, December 10, 1997.
- Kolpakov F., Pidchenko S., Hilchenko G. (1998). "Method for measuring blood pressure", Patent Russia № 2106796, March 20, 1998.
- Kolpakov F., Akulinichev A. (1999). Piezoquartz pressure transmitter with an elliptical resonating membrane, *Aerospace technics and technology*, Vol. 12, National Aerospace University (KhAI), ISSN 1727-7337, Kharkov, Ukraine, pp. 103-105.
- Kolpakov F., Dobrova V., et al. (1999). Estimation of time diagnostic parameters of blood pressure variation in frequency domain, *Proceeding of the 1999 Finish Signal Processing Symposium*, Oulu, Finland, pp. 189-193.
- Kolpakov F., Pidchenko S., Hilchenko G. (1999). "Method of linearization calibration characteristic piezoresonance transmitter with variable interelectrode gap", Patent Russia № 2127496, March 10, 1999.
- Kolpakov F., Slavinsky S. (2004). The sphygmography measuring converter "pressure-frequency" dynamic characteristics examination, *Measurement Science Review*, Vol. 4, Sect. 2, pp. 52-58.
- Kolpakov F., Pidchenko S., Taranchuk A., et al. (2009). Piezoresonance mehanotron in measurements of parameters warmly - vascular system of the human, *Radioelectronic and computer system*, Vol. 2, National Aerospace University (KhAI), ISSN 1814-4225, Kharkov, Ukraine, pp. 60-70.
- Kolpakov F., Pidchenko S. (2011). *Theory and fundamentals implementation of invariant piezoresonance systems*, National Aerospace University (KhAI), ISBN 978-966-662-222-1, Kharkov, Ukraine.
- Malov V. (1989). *Piezoresonance sensors*, Energoatomizdat, ISBN 5-283-01507-6, Moscow, Russia.
- Pidchenko S., Kolpakov F., Akulinichev A. (2000). Analysis of the characteristics of multi-frequency controlled crystal oscillator, *Measuring and Computing Devices in Technological Processes*, Vol. 3, Khmelnytsky national university, ISSN 2219-9365, Khmelnytsky, Ukraine, pp. 70-75.

- Pidchenko S., Taranchuk A., et al. (2002). "Pressure Sensor", Patent Ukraine № 44108 A, January 15, 2002.
- Pidchenko S., Taranchuk A., et al. (2003). "Pressure Sensor", Patent Ukraine № 59936 A, September 15, 2003.
- Pidchenko S., Taranchuk A. (2004). Identification of the thermal state of the crystal at the stage of oscillation, *Radioelectronic and computer system*, Vol. 3, National Aerospace University (KhAI), ISSN 1814-4225, Kharkov, Ukraine, pp. 36-42.
- Pidchenko S., Taranchuk A., Opolska A. (2010). Utilization Features of the Mechanotron for Information Measurement Systems, *Modern Problems of Radio Engineering, Telecommunication and Computer Science: Proceedings of the Xth International Conference TCSET'2010*, ISBN 978-966-553-875-2, February 23-27, Lviv-Slavske, Ukraine, P. 358.
- Taranchuk A., Pidchenko S., et al. (2002). The calculation of the temperature field piezoelectric pressure sensor with a modulated interelectrode gap, *Metrology and Computer Engineering: Proceedings of the III International Conference (Metrology – 2002)*, Sect. 2, Kharkov, Ukraine, pp. 139-141.
- Taranchuk A., Pidchenko S. (2005). Modelling of thermal processes in the piezoresonance sensors with modulated interelectrode gap, *Khmelnytsky State University's bulletin*, Vol. 1, Khmelnytsky national university, ISBN 978-966-330-114-3, Khmelnytsky, Ukraine, pp. 218-222.
- Taranchuk A., Pidchenko S., et al. (2008). Sphygmographic channel to study hemodynamic parameters of the cardiovascular system of man, *Khmelnytsky State University's bulletin*, Vol. 3, Khmelnytsky national university, ISBN 978-966-330-114-3, Khmelnytsky, Ukraine, pp. 47-52.
- Taranchuk A., Pidchenko S., Opolska A. (2010). Sphygmographic system of high accuracy registration of pulse fluctuations, *Medical and Biological Informatics and Cybernetics: Proceedings of the First Ukrainian Congress*, June 23-26, Kiev, Ukraine, P. 267.
- Taranchuk A., Pidchenko S., et al. (2010). "The transmitter with pressure-frequency sensor for sphygmographic research", Patent Ukraine № 53900, October 25, 2010.

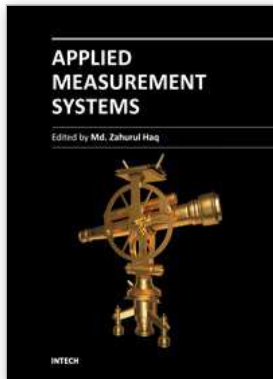

Applied Measurement Systems

Edited by Prof. Zahurul Haq

ISBN 978-953-51-0103-1

Hard cover, 390 pages

Publisher InTech

Published online 24, February, 2012

Published in print edition February, 2012

Measurement is a multidisciplinary experimental science. Measurement systems synergistically blend science, engineering and statistical methods to provide fundamental data for research, design and development, control of processes and operations, and facilitate safe and economic performance of systems. In recent years, measuring techniques have expanded rapidly and gained maturity, through extensive research activities and hardware advancements. With individual chapters authored by eminent professionals in their respective topics, Applied Measurement Systems attempts to provide a comprehensive presentation and in-depth guidance on some of the key applied and advanced topics in measurements for scientists, engineers and educators.

How to reference

In order to correctly reference this scholarly work, feel free to copy and paste the following:

Alla Taranchuk and Sergey Pidchenko (2012). Design Methodology to Construct Information Measuring Systems Built on Piezoresonant Mechanotrons with a Modulated Interelectrode Gap, Applied Measurement Systems, Prof. Zahurul Haq (Ed.), ISBN: 978-953-51-0103-1, InTech, Available from:

<http://www.intechopen.com/books/applied-measurement-systems/design-methodology-to-construct-information-measuring-systems-built-on-piezoresonant-mechatrons-with>

INTECH

open science | open minds

InTech Europe

University Campus STeP Ri
Slavka Krautzeka 83/A
51000 Rijeka, Croatia
Phone: +385 (51) 770 447
Fax: +385 (51) 686 166
www.intechopen.com

InTech China

Unit 405, Office Block, Hotel Equatorial Shanghai
No.65, Yan An Road (West), Shanghai, 200040, China
中国上海市延安西路65号上海国际贵都大饭店办公楼405单元
Phone: +86-21-62489820
Fax: +86-21-62489821