

. 1.

2

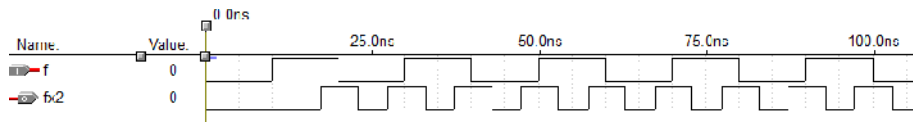

. 2.

2

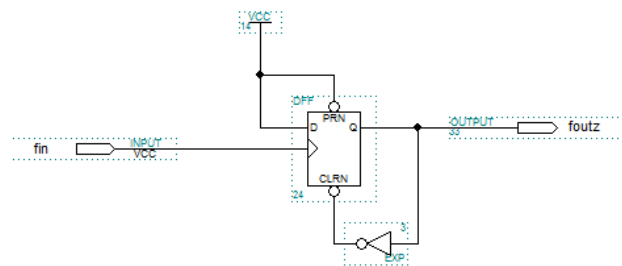

. 3.

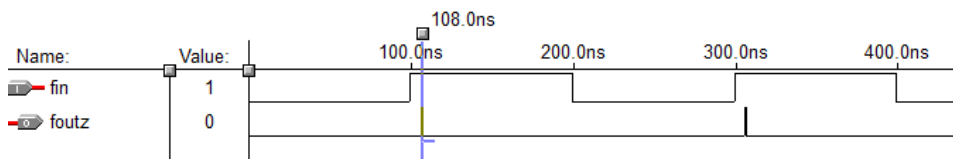

. 4.

$$F_{fx2} = \frac{1}{T_{in}} + \frac{1}{T_{in}} = \frac{2}{T_{in}} = 2 \cdot F_{in}, \quad (1)$$

T_{in} –
 F_{in} –

. 4

8

4

2

. 5 6

$$F_{fx2} = \frac{2}{T_{in}} + \frac{2}{T_{in} + 12 \cdot T_z} = \frac{2T_{in} + 24 \cdot T_z + 2T_{in}}{T_{in}^2 + 12 \cdot T_{in} \cdot T_z} \approx 4 \cdot F_{in}, \quad (2)$$

z –

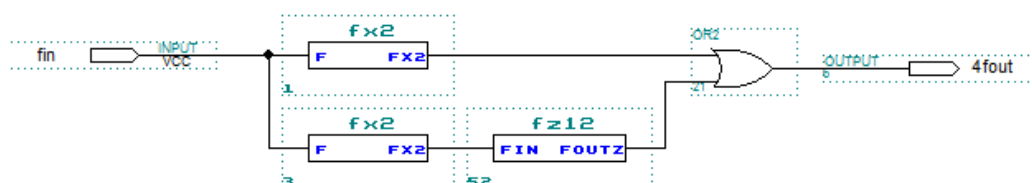

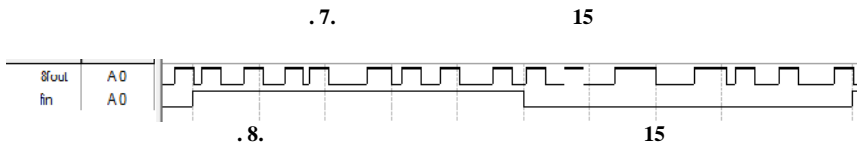
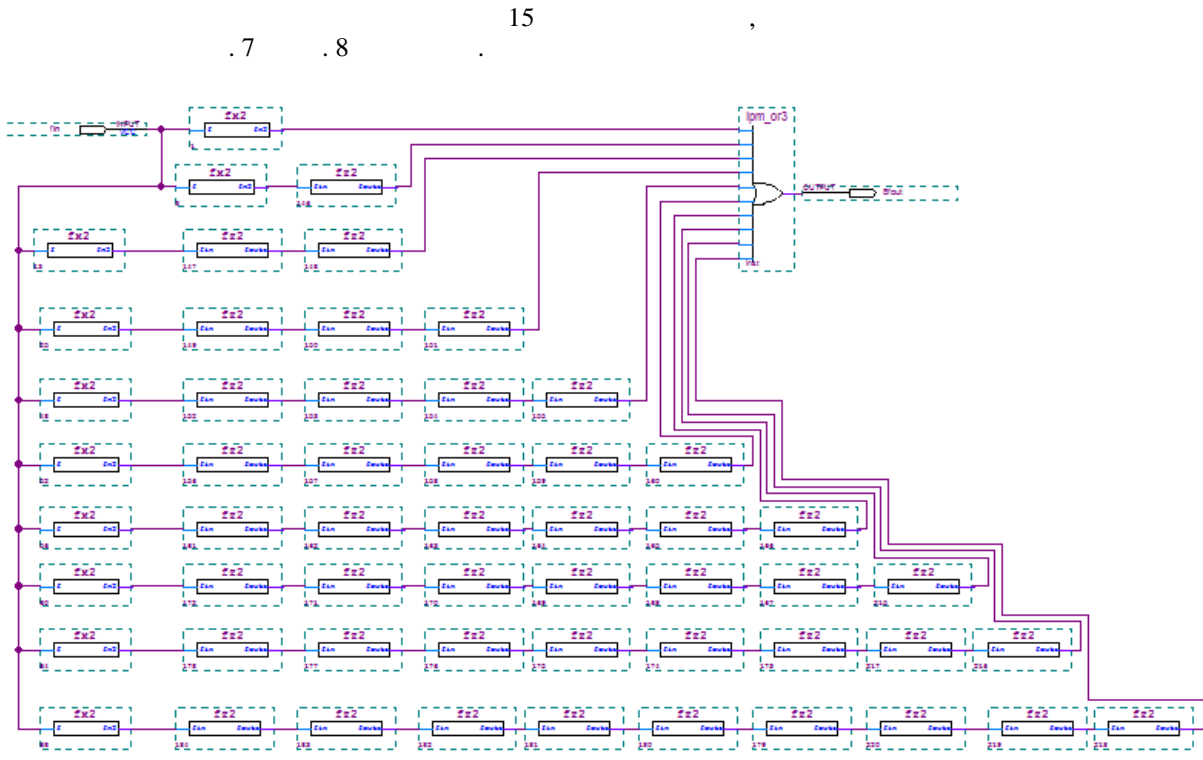
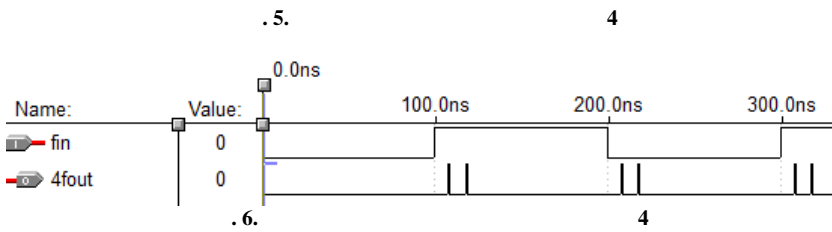

(. 9) (fx6)
 (. 10), Quartus [4]

count20. plus q, AND2, count20 minus -
 count1024.
 count20 adder.
 reg, countr20 reg D-
 fx6, 8 D-
 functab7x6. reg
 sinsaw square
 :
 sinsaw square
 D-
 dac[5..0] functab7x6

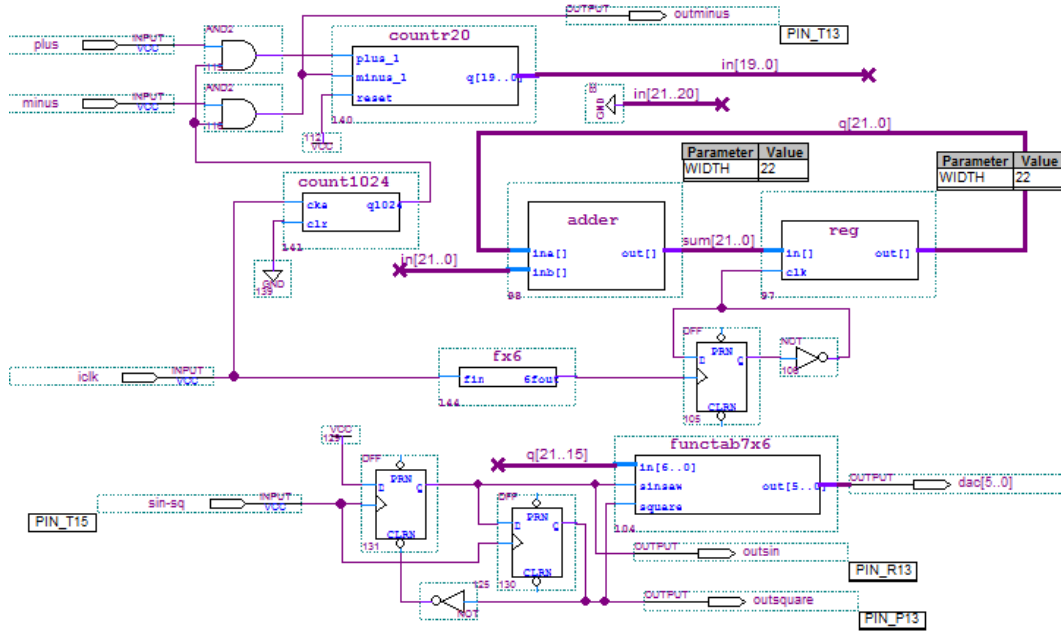

.9.

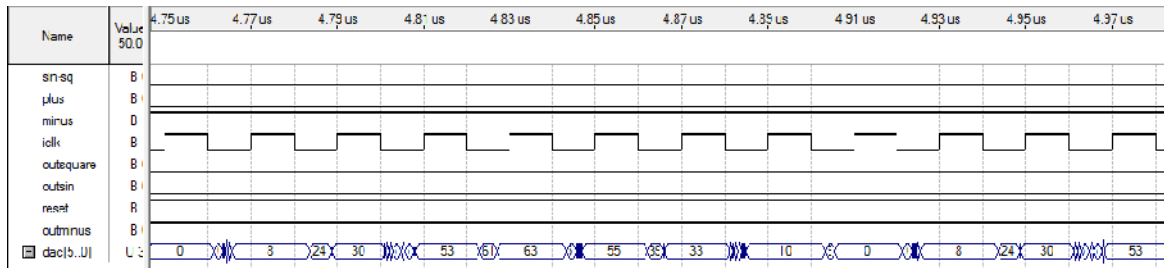

.10.

2,4 15.

() / . ; . . ;
 1979. – 394 .
 / //
 . – 2017. – 6. – . 187–190.
 " , 1999. – 768 .
 Quartus [] . –
<https://www.altera.com/products/design-software/fpga-design/quartus-prime/overview.html>.

References

Manassevich V. Sintezatory chastot (Teoriya i proektirovanie) / V. Manasevich ; per. s angl. ; pod red. A. S. Galina – M. : Svjaz' 1979. – 394 s.
 Petrushak V.S. Rozrobka cifrovogo generatora per odichnih signal v na baz prjamogo metodu sintezu chastoti dosl dzhennja roboti jogo funkcnal'nih blok v / V.S. Petrushak, S.V. Samoljuk // V snik Hmel'nic'kogo nac onal'nogo un versitetu. – 2017. – 6. – S. 187–190.
 Opadchij Ju.F. Analogovaja i cifrovaja jelektronika. Polnyj kurs / Ju.F. Opadchij, O.P. Gludkin, A.I. Gurov – M. : "Gorjachaja Linija-Telekom", 1999. – 768 s.
 Opis sistemi avtomatizovanogo proektuvannja Quartus [Elektronnij resurs]. – Rezhim dostupu : <https://www.altera.com/products/design-software/fpga-design/quartus-prime/overview.html>.

/Received : 6.2.2018 . /Printed :26.3.2018 .