

Запропонована модель зношування підшипника ковзання в умовах граничного тертя у вигляді залежності інтенсивності зношування від контактної тиску і швидкості ковзання. На основі моделі зношування вирішена зносоконтактна задача для циліндричного підшипника ковзання. Для ідентифікації параметрів зносостійкості розроблена теорія методу випробувань на знос за схемою «конус – три кульки». Наведено приклад реалізації методу розрахунку зносу підшипника ковзання. Отримані результати рекомендуються для прогнозування зношування підшипників ковзання з урахуванням впливу конструктивних і експлуатаційних факторів

Ключові слова: підшипник ковзання, зносоконтактна задача, модель зношування, випробування на знос, параметри зносостійкості

Предложена модель изнашивания подшипника скольжения в условиях граничного трения в виде зависимости интенсивности изнашивания от контактного давления и скорости скольжения. На основе модели изнашивания решена износоконтактная задача для цилиндрического подшипника скольжения. Для идентификации параметров износостойкости разработана теория метода испытаний на износ по схеме «конус – три шара». Приведен пример реализации метода расчета износа подшипника скольжения. Полученные результаты рекомендуются для прогнозирования износа подшипников скольжения с учетом влияния конструктивных и эксплуатационных факторов

Ключевые слова: подшипник скольжения, износоконтактная задача, модель изнашивания, испытания на износ, параметры износостойкости

CALCULATION-EXPERIMENTAL MODELING OF WEAR OF CYLINDRICAL SLIDING BEARINGS

A. Dykha

Doctor of Technical Sciences,
Professor, Head of Department
Department of wear resistance and
reliability of machines**
E-mail: tribosensor@gmail.com

R. Sorokatyi

Doctor of Technical Sciences,
Professor, Head of Department
Departments of Computer Science and
Information Technologies**
E-mail: rsorokatyi@gmail.com

O. Makovkin

PhD, Associate Professor*
E-mail: makovkin@ukr.net

O. Babak

PhD, Associate Professor*
E-mail: ang.babak@gmail.com

*Department of wear resistance and
reliability of machines

**Khmelnitskyi National University
Instytutska str., 11, Khmelnitskyi, Ukraine, 29016

1. Introduction

The current stage in development of tribology is characterized by creation of methods for calculating the wear of friction units. It was believed for a long time that creation of such methods is impossible because of an extreme complexity of wear processes. At the same time, if there are no methods of calculation at the stage of designing and machine creation, then respectively there will be no methods for predicting wear resistance and durability of the friction units. Development of analytical methods for calculating wear resistance of tribosystems is complicated by nonlinearity of wear models because of complex interrelationships of mechanical, thermophysical and frictional properties. To obtain correct results, analytical methods for calculating tribosystems require a number of parameters that characterize real operating conditions. Cylindrical sliding bearings in many manufacturing, transport and power machines are among the main components determining durability and reliability of the machine as a whole. Thus,

creation of calculation and experimental methods and models of wear resistance for predicting wear-related durability of cylindrical sliding bearings taking into account the variety of operating conditions is a focal scientific problem.

2. Literature review and problem statement

Creation of methods for calculation and wear test of cylindrical sliding bearings is currently being given considerable attention.

For example, on the basis of a cumulative wear model, solution of a tribocontact problem for a sliding bearing was performed in work [1]. In this case, the shaft shape was not cylindrical but had slight facets of various kinds. The proposed solution was rather complicated for practical implementation since it required breaking of the wear zone into discrete parts and did not take into account technological features of making shafts with a specified faceting.

In work [2], analysis of variation of the contact pressure during wear of the coating in a thrust sliding bearing was carried out at a nonlinear form of the wear law. Dependence of wear rate on the factors of velocity and contact pressure was taken as the law of wear. To describe deformation properties of the contacting materials, a nonlinear Winkler model was adopted. The proposed algorithm for solving the wear-contact problem for the thrust bearing will have material complications in the case of cylindrical bearing. This is because of the problems of a mathematical nature when nonlinear equations describing contact geometry in a cylindrical bearing are additionally used in the decision equations.

Solution of an inverse wear-contact problem for identifying parameters of dependence of the wear rate on pressure and sliding velocity with accounting for their distribution over the contact spot was made in [3]. On the basis of experimental study of wear by the «finger – disk» scheme, expressions were derived for determining these parameters. However, the assumption of permanence of the wear spot accepted in this work in accordance with the test pattern did not let use of the obtained solution for the test schemes with a variable contact (wear) spot of a «ball – ball» or «cone – ball» type.

A calculation-experimental method for determining tangential contact frictional stresses using a variational principle was proposed in work [4]. In this case, a quadratic functional of deviation of the experimental function of tangential stresses from the equilibrium condition was constructed. The experimental stress function and its parameters were determined using power approximation of the experimental data. In this case, disadvantage of the method for solving the contact problem was low accuracy since the approximation was only carried out over two experimental points.

The authors of paper [5] have carried out a theoretical analysis of kinetics of wear of spherical specimens in the process of testing on a four-ball friction machine. An assumption was made that the equation of wear kinetics corresponds to the second-order differential equation. However, the described kinetic model has a phenomenological character and is based on the principles of behavior of open thermodynamic systems. This approach involved use of a number of thermodynamic parameters of the system which are rather hard for establishing in practice.

The authors of [6] proposed theoretical dependences for a wear testing method using a standard four-ball scheme with determination of wear resistance parameters. The approximating function of the wear spot diameter on the friction path obtained by the results of wear tests was taken as the base of the method. The general methodology of this study can be used to develop a theory of test methods for other geometric schemes. The wear resistance parameters determined from the wear tests of steel balls cannot be applied to the calculation and modeling of bearing materials.

For numerical simulation of the wear process for a radial sliding bearing, the finite element method was used in [7]. In this case, the contact conditions were modeled by the Lagrange-Euler complex and evolution of local wear was modeled by the Archard equation. As a result of this simulation, dependences of the contact pressures on wear and the influence of the bearing clearance on these dependences were obtained. At the same time, the wear coefficients were determined from the linear dependence of wear rate on pressure and sliding velocity which is only characteristic of abrasive wear and is not prevalent for sliding bearings. In addition,

dimensional form of the wear law complicated analysis of effect of the determining factors on wear and tear.

A calculation-experimental method for determining viscous friction characteristics for a cylindrical sliding support using a pendulum scheme of damped oscillations was proposed in [8]. The method for determining lubricant viscosity can be recommended to obtain viscosity values in wear calculations of sliding bearings. At the same time, wear of the cylindrical sliding support was not taken into account.

In work [9], dependence of the surface layer stresses resulting from the shaft-sleeve contact interaction in the sliding bearing on its wear resistance was considered. Instead of contact pressures, surface stressed state which was numerically estimated by the finite element method was taken as the determining factor of the wear rate. It is difficult to use this approach in the engineering practice of calculating bearing wear at the design phase.

The work [10] was devoted to experimental study of friction losses in friction pairs made of metal-polymeric materials. In this case, dry friction was considered with no use of a lubricant which is not typical for cylindrical sliding bearings working in a boundary or even a liquid-friction mode.

The work [11] was devoted to technological methods of ensuring wear resistance of sliding bearing parts. A regular profile of lubrication grooves was proposed for the boundary lubrication mode. A surface layer with improved antifriction properties is formed in the process of discrete hardening. The work did not place emphasis on the effect of regular lubrication profiles on the wear resistance of the bearing parts.

Thus, further theoretical and experimental studies are needed to create methods for calculating cylindrical sliding bearings and their wear testing. On the one hand, these methods should be applicable in practical wear calculations at the design stage, and on the other hand, they must include parameters adequately corresponding the actual wear process.

3. The aim and objectives of the study

This work's objective was to create a calculation-experimental method for calculating the wear of sliding bearings based on a two-factor wear model (contact pressure – sliding velocity) with identification of their wear resistance parameters.

To achieve this goal, the following tasks were set:

- develop a model of bearing wear depending on the dimensionless complexes of determining factors of contact pressures and sliding velocity;
- on the basis of the wear model, solve the wear-contact problem for a cylindrical sliding bearing with deriving a dependence of degree of linear wear on the friction path in a closed species;
- obtain theoretical dependences for identification of wear resistance parameters in the model of bearing wear based on the results of laboratory wear tests by a «cone – three balls» scheme.

4. Solution of the wear-contact problem for a cylindrical sliding bearing

The wear-contact problem is the problem of determining maximum linear wear in the bearing depending on the friction

path (working life). In this case, the bearing parameters of design, loading and kinematics as well as regularity of wear depending on wear-resistance parameters were taken as the starting data.

By their design scheme, cylindrical sliding bearings represent an internal contact of two cylinders of close radii with a radial clearance Δ (Fig. 1). The shaft with radius R_1 is loaded with force Q and rotates at a sliding velocity V in the bearing bush 2 having radius R . In the process of force interaction of the shaft and the bearing bush, the contact pressure σ distributed over the arc of contact $2\varphi_0$ arises at the place of contact of two cylinders.

Assuming wear resistance of the shaft much greater than the wear resistance of the bushing (direct friction pair), an arc zone of wear with a maximum wear u_w value at the contact center is worn out during operation in the inner surface of the bushing.

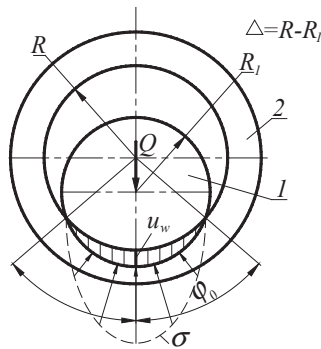

Fig. 1. Calculation scheme of a cylindrical sliding bearing

For analytical solution of the problem of the sliding bearing wear calculation, in addition to the indicated geometrical, force and kinematic parameters, a mathematical form of wear regularity is also taken as the initial value. Representation of such regularities in a form of dependence of the wear rate on the determining parameters of the process (contact pressure, sliding velocity, temperature, etc.) was of the greatest use. Here, we propose regularity (model) of wear in a form of a dimensionless set of determining factors:

$$\frac{du_w}{dS} = C_w \left(\frac{f\sigma}{HB} \right)^n \left(\frac{VR}{v} \right)^p, \quad (1)$$

where u_w is bearing wear; S is friction path; f is coefficient of friction in the shaft-bushing pair; σ is normal contact pressure; HB is hardness of the bushing material; V is sliding velocity; R is bearing (bushing) radius; v is kinematic oil viscosity; C_w, n, p are parameters of wear resistance.

In the basic dependence (1), value of the contact pressure will be determined from the mean values (equation of equilibrium):

$$\sigma = \frac{Q}{2bR\varphi_0}, \quad (2)$$

where Q is load acting on the bearing; b is width of the contact between the shaft and the bushing; φ_0 is half-angle of the contact between the shaft and the bushing.

The relationship of the maximum wear u_w and the contact angle is determined from geometry of the internal con-

tact of two cylinders with an initial radial clearance Δ from the dependence:

$$u_w(\varphi_0) = \Delta(\sec \varphi_0 - 1). \quad (3)$$

For further use, it is convenient to represent function $\sec \varphi_0 - 1$ in a form of a power approximation. For the range of changes in the contact angle $0 \dots \pi/2$ (Table 1), use the Excel program to construct graphical dependence of function $\sec \varphi_0 - 1$ on the contact angle φ_0 (Fig. 2) and obtain a power approximation of this function.

Table 1

Numerical dependences for the function of contact angle in the bearing

φ_0, rad	0.2	0.4	0.6	0.8	1.0	1.2	1.4
$\sec \varphi_0 - 1$	0.02	0.086	0.212	0.435	0.851	1.76	4.88

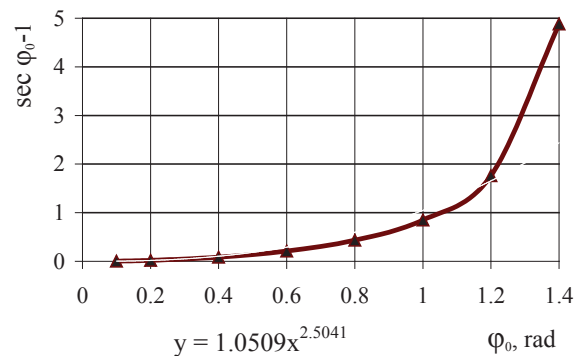

Fig. 2. Power approximation of function $\sec \varphi_0 - 1$ on the contact angle φ_0

With a sufficient accuracy, it can be assumed that

$$\sec \varphi_0 - 1 \approx \varphi_0^{2.5}. \quad (4)$$

Thus, expression (3) can be represented in the following form:

$$u_w = \Delta \varphi_0(s)^{\frac{2.5}{2}}. \quad (5)$$

Differentiate the dependence (5) in the friction path s :

$$\frac{du_w}{ds} = 2 \frac{1}{2} \Delta \varphi_0(s)^{\frac{1}{2}} \frac{d\varphi_0}{ds}. \quad (6)$$

Equate (1) and (6) and substitute into the left-hand side the expression for the contact pressure (2) to obtain:

$$c_w \left(\frac{VR}{v} \right)^p \left(\frac{f}{HB} \right)^n \left(\frac{Q}{2bR\varphi_0} \right)^n = 2 \frac{1}{2} \Delta \varphi_0(s)^{\frac{1}{2}} \frac{d\varphi_0}{ds}. \quad (7)$$

Transform (7) to the form:

$$\frac{c_w}{2.5\Delta} \left(\frac{VR}{v} \right)^p \left(\frac{fQ}{HB 2bR} \right)^n = \varphi_0^{n+1.5} \frac{d\varphi_0}{ds} \quad (8)$$

or

$$\frac{2c_w}{5\Delta} \left(\frac{VR}{v} \right)^p \left(\frac{fQ}{HB 2bR} \right)^n ds = \varphi_0^{n+1.5} d\varphi_0. \quad (9)$$

This is an ordinary differential equation with separating variables. Integrate equation (9) to obtain:

$$\frac{\varphi_0^{n+2.5}}{n+2.5} = \frac{2c_w}{5\Delta} \left(\frac{VR}{v} \right) \left(\frac{fQ}{HB2bR} \right)^n s + C. \quad (10)$$

Assuming that the contact angle $\varphi_0=0$ at the initial moment of the wear process ($s=0$), the integration constant $C=0$.

Thus, the dependence of the contact angle on the friction path takes the form:

$$\varphi_0 = \left[\frac{(n+2.5)2^{1-n}c_w}{5\Delta} \left(\frac{VR}{v} \right)^p \left(\frac{fQ}{HB bR} \right)^n s \right]^{\frac{1}{n+2.5}}. \quad (11)$$

Or finally, taking into account dependence (5), the calculation formula for dependence of the maximum wear u_w in the sliding bearing on the magnitude of the friction path s will be:

$$u_w = \Delta \left[\frac{(n+2.5)2^{1-n}c_w}{5\Delta} \left(\frac{VR}{v} \right)^p \left(\frac{fQ}{HB bR} \right)^n s \right]^{\frac{2.5}{n+2.5}}. \quad (12)$$

In the obtained formula (12), the wear resistance parameters C_w , n , p show the degree of influence of the determining factors of the bearing wear process. As a rule, their numerical values are determined experimentally by laboratory tests. On the one hand, these tests will not be cumbersome with the use of geometrically simple specimens and on the other hand, the test conditions tend to be as close as possible to the actual unit operating conditions in order to obtain a more adequate wear model. Further, the procedure for calculating wear resistance parameters from the results of laboratory wear tests is considered for a complete identification of formula (12).

5. Identification of wear resistance parameters for the method of wear test by the «cone – three balls» scheme

Balls, cylinders, rollers, rectangular prisms, etc. were used in laboratory tests as specimens. Here, it was proposed to use the «cone – three balls» scheme of test to determine wear characteristics. Standard 12.7 mm diameter steel balls made of steel SH15/1.3505 were used as control specimens. A conical specimen of a corresponding bearing material was used as a test specimen. Conical specimens are easily prepared and are characterized by the wear spot dimensions changing during the test. The change of the wear spot leads to a change of contact pressures which makes it possible to obtain a set of test results by the load characteristics without changing the external load on the conical specimen. Below, a calculation and experimental procedure for identifying wear resistance parameters C_w , n , p in the model of wear (1) for testing by the «cone – three balls» scheme is considered.

The calculation «cone – three balls» test scheme is shown in Fig. 3. Three balls 1, 2, 3 of the same radius R are situated on the plane so that their centers form an equilateral triangle $O_1O_2O_3$. The cone 4 with vertex angle γ is contacting the lower placed balls at points $A_1A_2A_3$. Force Q applied to

the cone is transmitted to the lower balls along perpendiculars to the cone generatrix with equal forces $Q_1=Q_2=Q_3$.

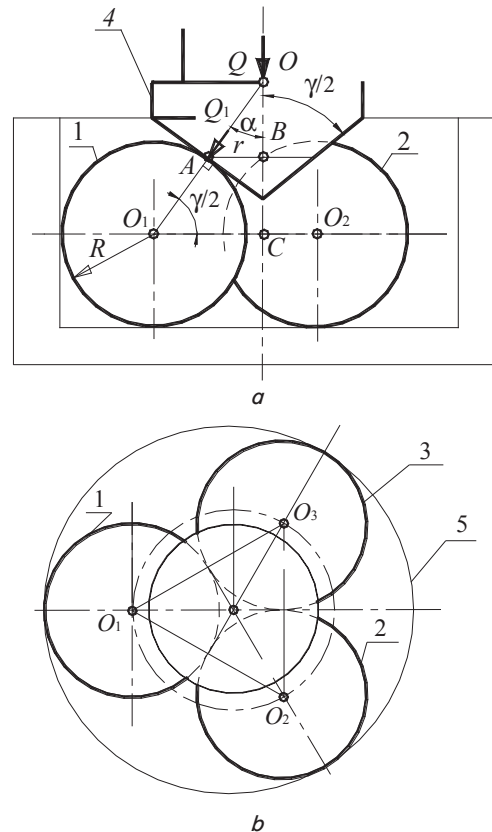

Fig. 3. The calculation «cone – three balls» test scheme: a – front view; b – top view

The cage 5 ensures immobility of the balls under action of loading from the vertical force and a moment around the vertical axis.

The forces acting on the balls are expressed through a common force by the relation:

$$Q_1 = Q_2 = Q_3 = \frac{Q}{3\cos(\gamma/2)}. \quad (13)$$

To determine linear sliding velocity of the cone on the balls, it is necessary to know the distance r from the cone rotation axis to the points of contact with the balls.

From similarity of the triangles OO_1C and OAB , the following is obtained:

$$r = O_1C \left(1 - \frac{R}{OO_1} \right). \quad (14)$$

The value of O_1C is defined as the radius of the circle circumscribed around the regular triangle $O_1O_2O_3$:

$$O_1C = \frac{2\sqrt{3}}{3} R.$$

Then from a right-angled triangle (Fig. 2):

$$OO_1 = \frac{O_1C}{\cos \gamma/2} = \frac{2\sqrt{3}R}{3\cos \gamma/2}.$$

After intermediate substitutions, the following is obtained:

$$r = R \left(\frac{2\sqrt{3}}{3} - \cos(\gamma/2) \right). \quad (15)$$

Take the shape of the worn-out cone surface as a circular groove with a profile radius a . Assume also that the contact pressure under the rigid wear-free ball is evenly distributed over the worn-out cone surface. Then the following relation holds:

$$\sigma = \frac{Q_1}{\pi a^2}. \quad (16)$$

The relation of the maximum wear u_w with dimensions of the wear spot a is determined from the geometry of contact of the conjugated cone of radius R with a cylinder of radius r . With a sufficient accuracy, the sought dependence is represented as:

$$u_w(S) = \frac{a(S)^2}{2R^*}, \quad (17)$$

where R^* is the equivalent radius in the cone – ball contact:

$$R^* = \frac{Rr}{R+r}.$$

In determining wear resistance parameters, use equivalent radius of the ball – cone contact in the model of wear resistance (1) instead of the bearing radius.

Represent the experimental dependence of the radius of a circular groove worn out in the cone as a power approximation:

$$a(S) = cS^\beta, \quad (18)$$

where c and β are the approximation parameters determined from the results of the wear tests.

Integrate the regularity of wear (1) to obtain an integral form of the model of cone wear:

$$u_w(S) = C_w \int_0^S \left(\frac{f\sigma(S)}{HB} \right)^n \left(\frac{VR^*}{v} \right)^p dS. \quad (19)$$

Substitute the expression for wear (17) in the left side of the obtained dependence and the expression for the contact pressure (16) in the right-hand side to obtain:

$$\frac{a^2(S)}{2R^*} = C_w \int_0^S \left[\left(\frac{fQ_1}{\pi a^2(S)} \right) \frac{1}{HB} \right]^n \left(\frac{VR^*}{v} \right)^p dS, \quad (20)$$

or taking into account (18) and integrating along the friction path, the following is obtained:

$$\frac{c^2 S^{2\beta}}{2R^*} = C_w \left(\frac{fQ_1}{c^2 \pi HB} \right)^n \left(\frac{VR^*}{v} \right)^p \frac{S^{1-2\beta n}}{1-2\beta n}. \quad (21)$$

From the condition of satisfiability of equation (21) for all values of S , it follows that:

$$2\beta = 1 - 2\beta n, \quad (22)$$

whence:

$$n = \frac{1-2\beta}{2\beta}. \quad (23)$$

To determine parameter p , tests should be carried out at two values of the sliding velocity V_1 and V_2 from which two groups of experimental data with approximating functions are obtained:

$$a_1 = c_1 S^\beta; \quad a_2 = c_2 S^\beta. \quad (24)$$

Consider the problem of determining parameters of wear according to the results of testing specimens with the contact spot $a(S)$ changing in the process of wear. The change of the wear spot causes the change in the values of the contact pressures $\sigma(a)$. The exponent n in expression (1) characterizes the rate of change of contact pressures during wear. It is directly related to the exponent β of the experimental dependence (18) which, accordingly, characterizes the rate of change of the contacting spot during wear. The relationship between n and β in the accepted wear regularity (1) is uniquely described by relation (23). Since the sliding velocity V in the considered ratios does not depend on the friction path S , it does not affect parameters n and β during the tests. In this case, the change in the slip velocity V affects just the scale factor C_w in expression (1). The above reasoning is confirmed by the test results.

Substitute expressions (24) into (21) and obtain a system of equations:

$$\left. \begin{aligned} \frac{c_1^2 \beta}{R^*} &= C_w \left(\frac{fQ_1}{c_1^2 \pi HB} \right)^n \left(\frac{V_1 R^*}{v} \right)^p; \\ \frac{c_2^2 \beta}{R^*} &= C_w \left(\frac{fQ_1}{c_2^2 \pi HB} \right)^n \left(\frac{V_2 R^*}{v} \right)^p. \end{aligned} \right\} \quad (25)$$

Divide the first equation by the second and obtain the following after transformations:

$$(c_1/c_2)^{2n+2} = (V_1/V_2)^p, \quad (26)$$

whence:

$$p = (2n+2) \frac{\lg(c_1/c_2)}{\lg(V_1/V_2)}. \quad (27)$$

To determine coefficient K_w , use one of the equations (25):

$$C_w = \frac{\beta c_1^{2n+2}}{R^*} \left(\frac{3\pi HB \cos \alpha}{fQ} \right)^n \left(\frac{v}{V_1 R^*} \right)^p. \quad (28)$$

Thus, the calculation-experimental procedure for identifying wear resistance parameters for the «cone – three balls» scheme of wear test based on the two-factor wear model of the sliding bearing (contact pressure, sliding velocity) was proposed.

6. Experimental setup and the test procedure

The experimental setup for the «cone – three balls» scheme of testing is shown in Fig. 4.

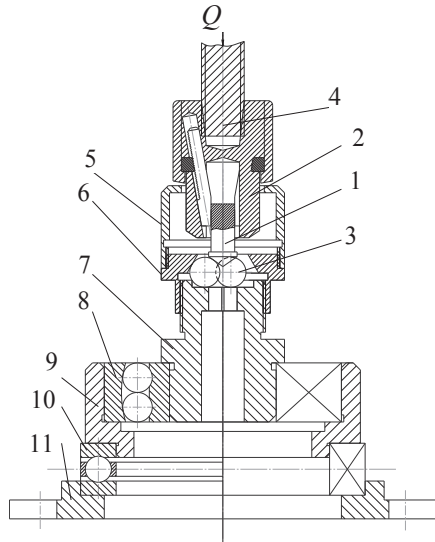

Fig. 4. The experimental setup

The test specimen 1 with a hardened conical surface is fixed in a universal self-centering drilling chuck 2. The specimen 1 is pressed with a vertical load Q onto the lower placed balls made of a ball bearing steel and is given a rotational motion from the spindle 4 of the experimental setup. The control ball specimens 3 are placed on the flat hardened surface of the support 7 and are centered by a special nut 6 with a conical working surface. Before testing, the cup 5 is filled with lubricant. A two-row self-centering bearing 10 located in the bottom housing 11 of the setup is used for self-adjustment of the specimens.

The tests were carried out under the following conditions.

The vertical load acting on the conical specimen was taken equal to $Q = 100$ N. The forces transmitted to the lower balls along the normal were determined from formula (2):

$$Q_1 = \frac{Q}{3 \sin 55^\circ} = \frac{100}{3 \sin 55^\circ} = 40.6 \text{ N.}$$

The cone angle of the conical sample was $\gamma = 110^\circ$. Diameter of the lower control ball specimens was $D = 12.7$ mm. The radius of the circular slipping path of the conical sample over the balls was calculated by formula (4):

$$r = R \left(\frac{2\sqrt{3}}{3} - \cos(\gamma/2) \right) = 6.35 \left(\frac{2\sqrt{3}}{3} - \cos 55^\circ \right) = 3.68 \text{ mm.}$$

The equivalent radius of the ball – cone contact will be $R^* = 2.35$ mm.

The tests were carried out at two rotation velocities of the setup spindle: $n_1 = 500 \text{ min}^{-1}$ and $n_2 = 1000 \text{ min}^{-1}$. These rotation velocities corresponded to linear sliding velocities for the conical sample:

$$V_1 = \frac{\pi n_1}{30} = \frac{3.14 \cdot 3.68 \cdot 500}{30} = 192 \text{ mm/s;}$$

$$V_2 = \frac{\pi n_2}{30} = 384 \text{ mm/s.}$$

The conical samples were made of tin-phosphorous bronze CuSn10P having hardness $HB = 90$ MPa. The balls were made of ball-bearing steel SH15/1.3505. The samples were lubricated with engine oil Magnum 15W-40 (TNK, Ukraine) having kinematic viscosity $\nu = 40 \text{ mm}^2/\text{s}$ at the operating temperature. Friction coefficient of bronze rubbing against lubricated steel was taken $f = 0.08$.

The cone wear in the form of an annular groove on its generatrix was measured by the width of the worn-out groove using an MБC-10 microscope with an accuracy of 0.05 mm. A special device (Fig. 5) for locating the conical sample in the measurement plane was used in measurements. The cone generatrix of the sample 1 was arranged parallel to the table of microscope 4 by turning the bracket 2 relative to the body 3 of the device.

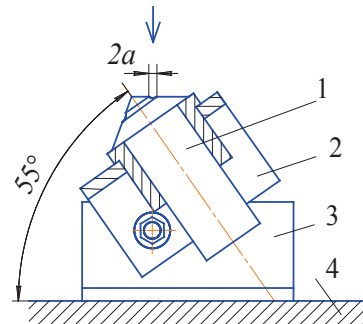

Fig. 5. Device for measuring width of the worn-out groove

The depth of the worn-out groove was taken as the maximum normal wear of the bushing. The degree of wear can be calculated from the width of the worn-out groove according to geometric relationships if the shape of the groove profile is admitted to be circular. To determine shape of the worn surface and the amount of linear wear u_w , a projector with a $\times 77$ magnification on the screen was used (Fig. 6).

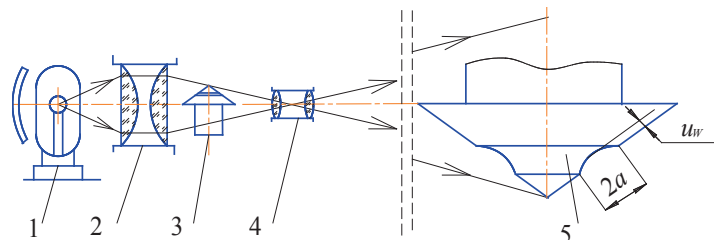

Fig. 6. Scheme of measuring the shape and depth of the worn surface: lighting lamp (1); lens (2); specimen (3); condenser (4); projection of the specimen on the screen (5)

Analysis of the worn out groove profile at a $\times 77$ magnification by the projector confirms its maximum closeness to a circular shape with a diameter equal to the ball diameter $D = 12.7$ mm. Thus, the amount of wear during testing depending on the width of the wear groove can be calculated from the above formula (6).

For example, a bronze specimen was tested under load $Q = 100$ N at sliding velocity $V = 0.19$ m/s and friction path $S = 342$ m. During the measurements, the depth of the worn-out groove on the projector screen was 12 mm, or $12/77 = 0.15$ mm taking in account the $\times 77$ magnification. The groove width was $2a = 205/77 = 2.66$ mm, respectively.

The amount of wear calculated from formula (6) depending on the half-width of the groove, was $u_W = 0.14$ mm. That is, discrepancy between the measured and calculated values did not exceed 7 % which permits the use of the calculated dependence of the depth of the groove of a circular profile on the groove width.

During the tests conducted to determine the wear resistance parameters, the wear values were measured every 10 minutes at a sliding velocity of 0.19 m/s and every 5 min at a sliding velocity of 0.38 m/s.

7. The results of tests and calculations of wear of the sliding bearings

To determine wear resistance parameters C_W, n, p of the model (1) of the plain bearing wear, conical specimens of bronze CuSn10P were tested. For statistical representativeness, each test cycle was carried out for 3 identical specimens. The averaged values obtained in measuring width of the worn-out groove are shown in Table 2. The value of the coefficient of variation characterizing scatter of the obtained measurement results was in the range $v = 0.15...0.2$ which indicates sufficient homogeneity of the experimental sample.

Table 2

Results of measuring width of the wear groove and calculating the wear depth

S, m	V ₁ =0.19 m/s		V ₂ =0.38 m/s	
	a, mm	u _W , mm	a, mm	u _W , mm
115	0.4	0.01	0.45	0.012
231	0.45	0.012	0.475	0.016
346	0.465	0.014	0.55	0.018
462	0.55	0.016	0.6	0.026
577	0.55	0.019	0.625	0.031
693	0.6	0.021	0.675	0.036

Graphical interpretation of the test results, that is, the dependence of the half-width of the wear spot and their power approximation are shown in Fig. 7. Fig. 7 also shows the power approximation with parameters and the magnitude of veracity of approximation R.

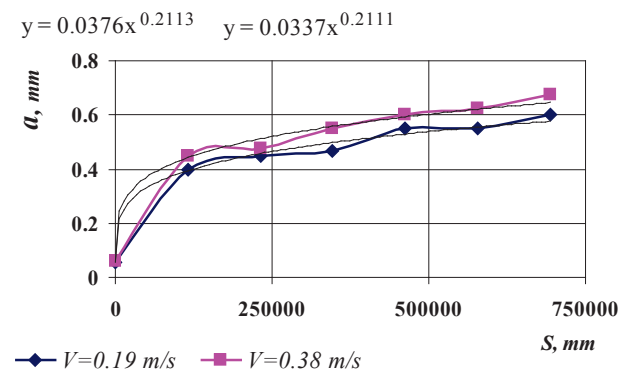

Fig. 7. Dependences of the half-width of the wear spot on the friction path and their power approximations

Thus, to determine the parameter of influence of the slip velocity on the wear resistance p , the following parameters of approximating functions of the form (24): were obtained: $c_1 = 0.0337$; $c_2 = 0.0376$; $\beta_1 \approx \beta_2 = \beta = 0.21$.

Further, calculate the wear resistance parameters C_W, n, p using formulas (23), (27), (28).

As a result of calculation when testing steel sliding on bronze, parameters of wear resistance were obtained: $n = 1.38$; $p = 0.68$; $C_W = 9.625 \cdot 10^{-9}$.

Using a similar procedure, wear resistance parameters for other bearing materials (brass, aluminum alloys) can be determined and used for a calculation assessment of the plain bearing wear. At the same time, using the averaged initial data characteristic for the working conditions of sliding bearings, these results can be used as normative parameters of wear resistance. To obtain values of the wear resistance parameters as close as possible to the real operating conditions, it is necessary to conduct laboratory tests according to the proposed scheme under specified conditions.

The following is an example of calculating wear of a sliding bearing with the found parameters of wear resistance.

Calculation will be carried out for materials of a friction pair «steel – bronze». Radial load on the bearing $Q = 500$ N; hardness of bronze CuSn10P $HB = 90$ MPa; width and radius of the bearing: $b = 20$ mm, $R = 20$ mm; radial clearance $\Delta = 0.1$ mm. Lubricant Magnum 15W-40 oil (TNK, Ukraine) was used with viscosity $\nu = 40$ mm²/s; coefficient of friction $f = 0.08$. Sliding velocity was assumed equal to 1 m/s which corresponds to the rotation frequency of the bearing shaft 475 min⁻¹. The initial data were substituted into the formula for calculating wear (12) and the results of calculating wear as a function of the friction path are presented in Table 3.

Table 3

Results of calculating wear u_W of the sliding bearing as a function of friction path S and working time t

S, km	10	10 ²	10 ³	10 ⁴
t, hr	1.5	15	150	1500
u _W , mm	4	17	76	338

Beside calculation of wear for the specified lifetime, dependence (12) allows one to analyze effect of design and operation parameters of bearings on their wear. This makes it possible to select optimal parameters of bearings at the stage of design preparation of the machine by the criterion of maximum wear resistance. Fig. 8 shows the graphs of influence of sliding velocity and load on the bearing wear obtained from the dependence (12).

Analysis of the obtained results has shown that all obtained dependences for the bearing wear were nonlinear. This is because of the type of the obtained calculated dependence (12). Such a character of influence of determining factors is caused by the features of geometry of the sliding bearing when the contact spot (contact arc) changes during the wear process which leads to a change in the contact pressures and, correspondingly, the wear rate. Besides, the proposed wear model in a nonlinear form (1) with wear resistance indexes n and p can adequately take into account almost all wear mechanisms including abrasive wear at $n = 1$. The calculated values of wear are consistent with the operational data of the sliding bearing wear.

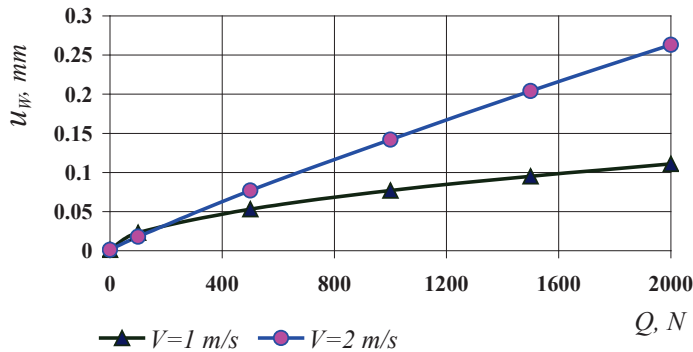

Fig. 8. Effect of sliding velocity and load on wear of the slide bearing

8. Discussion of the results obtained in computational and experimental modeling of wear of cylindrical plain bearings

The resulting calculation model (12) for estimating wear of sliding bearings assumes a simple algorithm for obtaining wear values from the friction path under given operation conditions. This was achieved through the use of certain assumptions in solution of the wear-contact problem. Firstly, a uniform distribution of contact pressures over the wear spot was taken for average values. Secondly, difficult for integral-differential transformations trigonometric dependence of wear on the contact angle (3) was approximated by plain power dependence (5). As a rule, known solutions require numerical algorithms to overcome mathematical difficulties. At the same time, in solving the problem, this approach has allowed us to use a nonlinear model of wear from the determining factors (1) which adequately describes the actual wear processes. It is impossible to obtain numerical results using formula (12) without the values of the wear parameters C_w , n , p . That is, the wear model (12) can be applied in practice if an algorithm for determining parameters of this regularity is known. It is the parameters that enable quantitative estimation of the effect of determining factors (pressure and slip velocity). The wear parameters can only be established by the test results which makes the model approximated to the real tribosystem operation conditions.

The procedure for determining parameters of wear models was developed based on solution of an inverse wear-contact problem. In this case, dependences for calculating parameters (23), (27), (28) were obtained according to the adopted mathematical form of the wear law (1), the equilibrium condition (16), the geometric condition of continuity in the contact (17) and the wear test results. In this process, a proper choice of scheme of laboratory wear tests is very important. The scheme to be chosen for the tests should be one which mostly corresponds to the real tribounit as to its geometric and tech-

nological features. For example, the widely used four-ball test scheme is suitable for the tribounits in which a linear or dot contact takes place (toothed drives, cam mechanisms). For the conjunctions in which the contact spot is commensurable with the dimensions of the contacting bodies (slide bearings, ball bearings), it is preferable to use the proposed «cone – three balls» scheme more adequately corresponding to the actual contact.

Besides, it is advisable to use schemes when the contact pressure changes during the test due to a change in the wear spot which allows one to have results for the pressure range from the results of tests of one specimen. In particular, the proposed «cone – three balls» scheme applies to this test scheme.

As a result, based on the obtained model of bearing wear, one can:

- predict bearing wear under various conditions on contact pressures and sliding velocities at the stage of design calculation of the friction unit;
- optimize design and operation parameters of the friction unit by the wear criteria.

The proposed approach does not ensure absolute correspondence to the actual course of the wear process but is an indispensable step in development of computational engineering methods for predicting wear resistance of friction units. Further studies in this direction should be carried out by extending the proposed methodology to other friction units of machines and the corresponding schemes of laboratory wear tests.

9. Conclusions

1. A model of wear of a sliding bearing in conditions of boundary friction was proposed in a form of a nonlinear dependence of the wear rate on the determining factors, i. e. contact pressure and sliding velocity. The wear model was presented in a form of dimensionless complexes taking into account geometric, kinematic, friction and lubrication characteristics of sliding bearings.

2. The wear-contact problem for cylindrical sliding bearings was solved. The dependence for average pressures in the bearing and the approximating function of linear wear on the contact arc were used as determining equations. The closed-form solution was obtained as a dependence of wear on the friction path.

3. A calculation-experimental procedure for identifying parameters of wear resistance for the wear tests by the «cone – three balls» scheme was developed based on the two-factor model of wear. Calculation dependences were obtained based on solution of an inverse wear-contact problem for a cylindrical sliding bearing with the results obtained in wear tests of conical bronze specimens with a variable wear spot and two sliding velocities taken as a base.

References

1. Chernets, M. V. Prediction of the life of a sliding bearing based on a cumulative wear model taking into account the lobing of the shaft contour [Text] / M. V. Chernets // Journal of Friction and Wear. – 2015. – Vol. 36, Issue 2. – P. 163–169. doi: 10.3103/s1068366615020038
2. Soldatenkov, I. A. Evolution of contact pressure during wear of the coating in a thrust sliding bearing [Text] / I. A. Soldatenkov // Journal of Friction and Wear. – 2010. – Vol. 31, Issue 2. – P. 102–106. doi: 10.3103/s1068366610020029
3. Mezrin, A. M. Determining local wear equation based on friction and wear testing using a pin-on-disk scheme [Text] / A. M. Mezrin // Journal of Friction and Wear. – 2009. – Vol. 30, Issue 4. – P. 242–245. doi: 10.3103/s1068366609040035

4. Dykha, A. V. Distribution of friction tangential stresses in the Courtney-Pratt experiment under Bowden's theory [Text] / A. V. Dykha, A. G. Kuzmenko // Journal of Friction and Wear. – 2016. – Vol. 37, Issue 4. – P. 315–319. doi: 10.3103/s1068366616040061
5. Bulgarevich, S. B. Kinetics of sample wear on four-ball friction-testing machine using lubricants of different consistencies [Text] / S. B. Bulgarevich, M. V. Boiko, K. S. Lebedinskii, D. Yu. Marchenko // Journal of Friction and Wear. – 2014. – Vol. 35, Issue 6. – P. 531–537. doi: 10.3103/s106836661406004x
6. Dykha, A. V. Solution to the problem of contact wear for a four-ball wear-testing scheme [Text] / A. V. Dykha, A. G. Kuzmenko // Journal of Friction and Wear. – 2015. – Vol. 36, Issue 2. – P. 138–143. doi: 10.3103/s1068366615020051
7. Rezaei, A. Adaptive finite element simulation of wear evolution in radial sliding bearings [Text] / A. Rezaei, W. Van Paeppegem, P. De Baets, W. Ost, J. Degrieck // Wear. – 2012. – Vol. 296, Issue 1-2. – P. 660–671. doi: 10.1016/j.wear.2012.08.013
8. Dykha, A. Determining the characteristics of viscous friction in the sliding supports using the method of pendulum [Text] / A. Dykha, V. Aulin, O. Makovkin, S. Posonskiy // Eastern-European Journal of Enterprise Technologies. – 2017. – Vol. 3, Issue 7 (87). – P. 4–10. doi: 10.15587/1729-4061.2017.99823
9. Vynar, V. A. Influence of the Stress-strain State on the Wear Resistance of the Surface of 40Kh Steel after Discrete Electromechanical Treatment [Text] / V. A. Vynar, M. O. Dykha // Materials Science. – 2013. – Vol. 49, Issue 3. – P. 375–381. doi: 10.1007/s11003-013-9625-z
10. Kryshchtopa, S. Examining the effect of triboelectric phenomena on wear-friction properties of metal-polymeric frictional couples [Text] / S. Kryshchtopa, L. Kryshchtopa, I. Bogatchuk, I. Prunko, V. Melnyk // Eastern-European Journal of Enterprise Technologies. – 2017. – Vol. 1, Issue 5 (85). – P. 40–45. doi: 10.15587/1729-4061.2017.91615
11. Kindrachuk, M. The friction mechanism between surfaces with regular micro grooves under boundary lubrication [Text] / M. Kindrachuk, O. Radionenko, A. Kryzhanovskiy, V. Marchuk // Aviation. – 2014. – Vol. 18, Issue 2. – P. 64–71. doi: 10.3846/16487788.2014.926642

Розглянуто задачу визначення картини усталеного трифазного режиму руху зернистого заповнення у поперечному перерізі циліндричної камери, що обертається навколо горизонтальної осі. Застосовано аналітико-експериментальний метод дослідження. Визначено положення квазітвердотільної зони невідного падіння і зсувного шару заповнення та розподіл швидкостей у нормальних перерізах потоків. Виявлено залежності характеристик картини руху від параметрів системи. Результати розрахунку картин добре збігаються із експериментальними даними

Ключові слова: зернисте заповнення, обертова камера, трифазний режим руху, картина руху, візуалізація

Рассмотрена задача определения картины установившегося трехфазного режима движения зернистого заполнения в поперечном сечении цилиндрической камеры, вращающейся вокруг горизонтальной оси. Применен аналитико-экспериментальный метод исследования. Определено положение квазитвердотельной зоны несвободного падения и сдвигового слоя заполнения и распределение скоростей в нормальных сечениях потоков. Выявлены зависимости характеристик картины движения от параметров системы. Результаты расчета картин хорошо совпадают с экспериментальными данными

Ключевые слова: зернистое заполнение, вращающаяся камера, трехфазный режим движения, картина движения, визуализация

UDC 621.926.5 : 539.215

DOI: 10.15587/1729-4061.2017.110444

MODELING A FLOW PATTERN OF THE GRANULAR FILL IN THE CROSS SECTION OF A ROTATING CHAMBER

Yu. Naumenko

Doctor of Technical Sciences,

Associate Professor

Department of construction, road,
reclamation, agricultural machines
and equipmentNational University of Water
and Environmental Engineering
Soborna str., 11, Rivne, Ukraine, 33028
E-mail: informal9m@i.ua

1. Introduction

Various drum-type machines remain basic equipment for the multi-tonnage processing of granular materials in many

industrial sectors. This is predetermined by a number of operational and economic advantages of such equipment.

The utmost simplicity of the design of drum machines, however, is paradoxically combined with the behavior of the