

Oleksandr Rudyk 

Ph.D., Associate Professor,
Khmelnyskyi National University,
Khmelnyskyi, Ukraine
yuhymovych@gmail.com

Vadym Bourdelnyi,

Undergraduate,
Khmelnyskyi National University,
Khmelnyskyi, Ukraine
vadimburdel2003@gmail.com

Vitaly Kaplun,

Undergraduate,
Khmelnyskyi National University,
Khmelnyskyi, Ukraine
vitalik.kaplun.2001@gmail.com

Oleg Kudin,

Undergraduate,
Khmelnyskyi National University,
Khmelnyskyi, Ukraine
okudin33@gmail.com

PROSPECTS FOR USING SOLIDWORKS IN MODERN EDUCATION

Annotation. SolidWorks is a CAD/CAE-system of automated design and engineering analysis of modern education. With its help, the parts of the stand for straightening deformed stamped wheels of passenger cars were designed, and in the SolidWorks Simulation application, the static strength of one of the parts of the tested stand – the rocker arm – was determined.

Key words: *SolidWorks, SolidWorks Simulation, wheels, discs, adjustment (editing), stand, rocker arm.*

Анотація. *SolidWorks – CAD/CAE-система автоматизованого проектування та інженерного аналізу сучасної освіти. З її допомогою спроектовані деталі стенду для правки деформованих штампованих дисків коліс легкових автомобілів, а у додатку SolidWorks Simulation визначена статична міцність однієї з деталей досліджуваного стенду – коромисла.*

Ключові слова: *SolidWorks, SolidWorks Simulation, колеса, диски, правка, стенд, коромисло.*

Introduction. Modern education is one of the most important subsystems of the social sphere of the state, which ensures the process of acquiring systematized knowledge, abilities and skills by a person for their effective use in professional activities.

Today's graduates must demonstrate not only good professional training, but also fully meet the requirements of modern life. In connection with this, professional education in the conditions of modern reality acquires special relevance and significance. The basis of vocational training is the principle of continuity, which implies a mandatory transition for a specialist from one educational degree to another, provided that he confirms the corresponding level of qualification. A mandatory condition of continuous professional education should be its methodically thought-out construction, which increases efficiency and facilitates the specialist's task.

Informatization of modern education is the introduction of information technologies into the educational process in accordance with the requirements of the world community, improving the quality of general education and professional training of specialists based on the wide use of computing and information technology.

CAD/CAE systems are used in engineering for automated design and engineering analysis, one of which is SolidWorks [1; 2].

It allows you to create a part model using sketch objects (polygon, circle, line, axis); creation of the basis, planes, element by intersections; adding cutouts, rounding; by changing elements; mirror reflection of half of the part; applying and changing dimensions; drawing, copying and pasting profiles.

The SolidWorks application – SolidWorks Simulation CAE system allows [3; 4]:

- select the parameters of the analysis of the stress state of the part by the finite element method (FEM);
- assign the material of the part;
- apply restrictions for the calculation of the MSE detail;
- apply load to certain planes, faces or elements of the part;
- analyse the model and the process of creating the MSE grid;
- create graphs of equivalent stresses, resulting displacement, equivalent deformations, safety margin.

Analysis of the latest research. It is known that depressions and cracks on the wheel rims of cars are formed as a result of:

- the car hitting the pits, which leads to the breakdown of the suspension;
- uneven tire wear;
- problems with steering traction;
- violation of the camber and toe-in of the wheels, which causes the tires to slip relative to the road, reduces the force of their adhesion to the supporting surface, increases tread wear, etc. [5].

The main reasons for the deterioration of the technical characteristics of tires are shock loads while driving at high speeds on roads with a low-quality surface. In turn, beating the wheel:

- causes its imbalance relative to the axis;
- reduces the force of adhesion of tires to the supporting surface;
- reduces the service life of tires, shock absorbers, and steering elements.

The basic part of the wheel is the disc, the geometric parameters and stiffness of which significantly affect the safety of movement and the stability of the car

during movement. Under the action of shock loads, local deformations of the disk occur [5].

To ensure the further use of the disk, it is necessary to restore its geometric indicators. And although restoring the geometry of the wheel rim does not require significant material costs, it requires special equipment – adjustment (editing) stands.

Therefore, the authors [5] considered the use of SolidWorks on the example of solid-state design and the subsequent verification of the static strength of one of the parts of the stand for straightening deformed stamped discs of passenger car wheels – the rocking lever.

The research stand is designed for straightening deformed stamped discs of passenger car wheels along the rim and its base.

The stand is stationary, with a manual screw drive [5]. The method of editing the rim profile is rolling with rollers:

- the faceplate disk is fixed on the rotating shaft;
- support and pressure rollers affect the damaged areas with a force sufficient to restore the geometry of the disk, which leads to the complete elimination of its deformation.

According to the researchers' calculations [5], it was established that the static strength of the rocker arm is ensured, but the stand may turn out to be inoperable due to insufficient strength of its other parts.

The aim of the article. The purpose of this work was to determine the static strength of the next part of the test stand - the rocker arm ([5] - item 1 in fig. 1) using the software product for creating SolidWorks graphics and the built-in module for strength calculations - SolidWorks Simulation [6; 7].

Research Methodology. First, in SolidWorks [8; 9], according to the drawing of the rocker arm (fig. 1, a), its model (fig. 1, b) was created.

The SolidWorks Simulation software module [10 - 12] was applied to the rocker model: static analysis was chosen as the type of study of its stress-strain state.

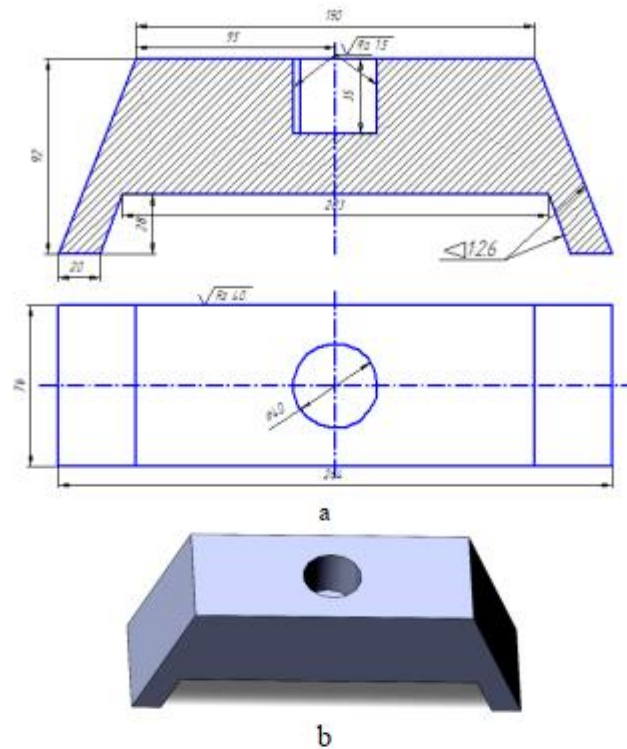
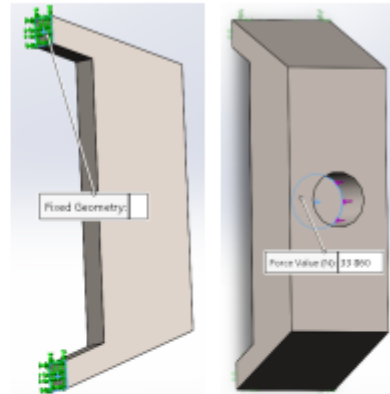

Fig. 1. Rocker arm drawing (a) and its 3D model (b)

Research results. When conducting a static analysis of the rocker model:

- determined the material of the part (steel 20KHN3A DEST 4543-71 – fig. 2);
- according to the calculation scheme, restrictions were added to the rocker arm model (fig. 2, a) and loads were applied (fig. 2, b);
- divided the model into elements connected at nodes (the finite element analysis program considered the model as a grid – fig. 3);
- constructed a stiffness matrix and synthesized a finite-element model of the rocker arm from its individual elements (taking into account the conditions for securing the rocker arm at the nodal points);
- solved the resulting system of algebraic equations and determined the components of the stress-strain state of the rocker arm model (fig. 4-7).

Properties	
Name:	Alloy steel
Model type:	Linear Elastic Isotropic
Default failure criterion:	Max von Mises Stress
Yield strength:	6,20422e+08 N/m ²
Tensile strength:	7,23826e+08 N/m ²
Elastic modulus:	2,1e+11 N/m ²
Poisson's ratio:	0,28
Mass density:	7 700 kg/m ³
Shear modulus:	7,9e+10 N/m ²
Thermal expansion coefficient:	1,3e-05 /Kelvin



a

b

c

Fig. 2. Properties of 20KH3A steel (a), limitations of the rocker arm model (b) and application of external loads to it (c)

Mesh Details	
Study name	
Details Mesh type	Solid Mesh
Mesher Used	Standard mesh
Automatic Transition	Off
Include Mesh Auto Loops	Off
Jacobian points for High quality mesh	4 points
Element size	10.3069 mm
Tolerance	0.515347 mm
Mesh quality	High
Total nodes	10985
Total elements	6966
Maximum Aspect Ratio	3.2752
Percentage of elements with Aspect Ratio < 3	99.9
Percentage of elements with Aspect Ratio > 10	0
Percentage of distorted elements	0
Number of distorted elements	0
Time to complete mesh(hh:mm:ss)	00:00:01
Computer name	

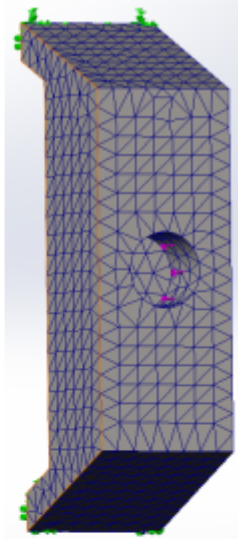

a

b

Fig. 3. Grid parameters (a) and its display (b) on the rocker arm model

It was found that the maximum Von Mises nodal stresses (74.84 MPa, node 10682 – fig. 4), URES displacement (0.02721 mm, node 817 – fig. 5) and equivalent strain ESTRN (0.0002418 mm, element 2436 – fig. 6) do not exceed permissible values.

At the same time, the minimum safety factor of the rocker arm model is located at node 10682 and is $k = 8.29$ (fig. 7), which is more than the permissible $[k] = 3$.

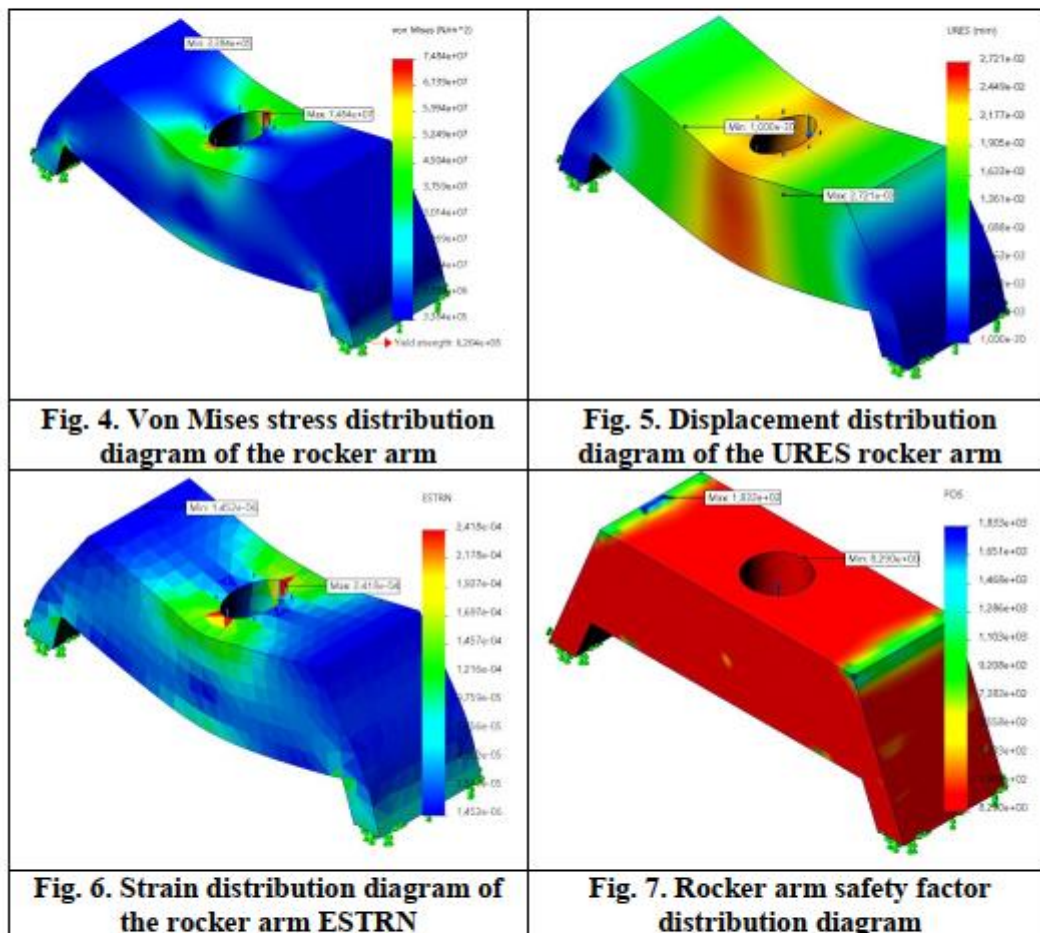

Conclusions. Thus, when using SolidWorks, the workability of the rocker arm of the stand for correcting deformed stamped discs of passenger car wheels has been proven, which allows the use of this CAD/CAE-system in modern education.

References

1. Oleksandr Rudyk, Pavlo Kaplun, Volodymyr Gonchar. Problems of two-wheeled vehicle repair / *Actual problems in the system of education: general secondary education institution – pre-university training – higher education institution* (ISSN 2786-5487 online). 2024. № 4. P. 68 - 77. URL: <https://jrnl.nau.edu.ua/index.php/APSE/article/view/18722> (last accessed: 2025/02/15).
2. Oleksandr Rudyk, Roman Kovalenko, Andrii Lavrenchuk, Daniil Hromov. Application of innovative technologies when researching the performance of road transport. *Actual problems in the system of education: general secondary education institution – pre-university training – higher education institution* (ISSN 2786-5487 online). 2024. № 4. P. 78 - 90. URL: <https://jrnl.nau.edu.ua/index.php/APSE/article/view/18723/25987> (last accessed: 2025/02/15).
3. Rudyk O. Yu. The use of computers in scientific research / O. Yu. Rudyk, Yu. Yu. Vasyura. *Integration of Education, Science and Business in the Modern Environment: Winter Debates: abstracts of the 1st International Scientific and Practical Internet Conference, February 6-7, 2020.* – Dnipro : WayScience, 2020. P. 123 - 127. URL: <http://www.wayscience.com/wp-content/uploads/2020/02/TOM-3-Zbirmik-1-mizhnarodna-nauk-prakt-int.-konf-Winter-Debates-1.pdf> (last accessed: 2025/02/15).
4. Псьол Сергій. Застосування комп'ютерного моделювання для розрахунків автомобільного транспорту / Сергій Псьол, Олександр Диха, Олександр Рудик, Костянтин Голенко. *Збірник наукових праць Національної академії Державної прикордонної служби України. Серія: педагогічні науки* / гол. ред. О. В. Діденко. Хмельницький : Видавництво НАДПСУ, 2023. № 1(32). С. 148 - 170. – URL: <https://periodica.nadpsu.edu.ua/index.php/pedzbirnyk/article/view/1322> (last accessed: 2025/02/15).

5. Rudyk O. Yu. Application of information technologies on the example of SolidWorks / O. Yu. Rudyk, O. I. Sokolov. *Збірник наукових праць за матеріалами I Міжнародної науково-практичної конференції «Вища технічна освіта XXI століття: виклики, проблеми, перспективи», присвяченої 50-річчю від часу заснування Донбаської національної академії будівництва і архітектури*, 15–16 грудня 2022 р., м. Краматорськ – м. Івано-Франківськ : ДонНАБА. 2022. С. 336 - 341. URL: <https://dspace.dsau.dp.ua/bitstream/123456789/9684/1/6.pdf> (last accessed: 2025/02/15).

6. Dykha Oleksandr. Continuous education in the educational program «Road transport» / O. Dykha, O. Rudyk. *Actual problems in the system of education: general secondary education institution – pre-university training – higher education institution*. 2023. № 3. P. 120-129. URL: <https://jrn1.nau.edu.ua/index.php/APSE/article/view/17687/24991> (last accessed: 2025/02/15).

7. Рудик О. Ю. SolidWorks – CAD/CAE-система технічних вузів / О. Ю. Рудик, П. В. Каплун. *Science, society, education: topical issues and development prospects: Abstracts of the 2nd International scientific and practical conference. SPC «Sci-conf.com.ua»*. Kharkiv, Ukraine, 2020. P. 249 - 253. URL: <http://sci-conf.com.ua/ii-mezhdunarodnaya-nauchno-prakticheskaya-konferenciya-science-society-education-topical-issues-and-development-prospects-20-21-yanvarya-2020-goda-harkov-ukraina-arhiv/> (last accessed 2025/02/15).

8. Рудик О. Ю. SolidWorks як інноваційний засіб вивчення дисциплін автомобільного профілю / О. Ю. Рудик, О. В. Диха. *Системні технології*. 2020. № 3 (128). С. 21 - 35. URL: <https://journals.nmetau.edu.ua/index.php/st/article/view/178/92> (last accessed: 2025/02/15).

9. Rudyk Oleksandr. SolidWorks as an innovative means of researching automotive engineering / O. Rudyk, M. Barnych, O. Humeniuk, V. Shchur *Actual problems in the system of education: general secondary education institution – pre-*

university training – higher education institution. 2023. № 3. С. 130 - 141. URL: <https://jrn1.nau.edu.ua/index.php/APSE/article/view/17688/24992> (last accessed: 2025/02/15).

10. Рудик О. Застосування SolidWorks для підготовки висококваліфікованих фахівців / О. Рудик, П. Каплун, В. Гончар. *Актуальні проблеми в системі освіти: заклад загальної середньої освіти – доуніверситетська підготовка – заклад вищої освіти*. 2022. № 2. С. 699 - 706. URL: <https://jrn1.nau.edu.ua/index.php/APSE/issue/view/879> (last accessed: 2025/02/15).

11. Рудик О. Ю. Застосування SolidWorks у навчальному процесі / О. Ю. Рудик Н. С. Маріїн, С. І. Ярошук . *Матеріали IV Всеукраїнської науково-практичної Інтернет-конференції «Ресурсно-орієнтоване навчання в «3D»: доступність, діалог, динаміка»*. Полтава : КУЕП ПДАА, 2020. С. 96 - 100. URL: <http://acup.poltava.ua/wp-content/uploads/2020/02/Збірник-2020-0203.pdf> (last accessed: 2025/02/15).

12. Psol S. V. Using SolidWorks to ensure passability of automotive equipment / S. V. Psol, Y. Leshchak, O. Yu. Rudyk. *Achievements and prospects of modern scientific research: Abstracts of the 2nd International scientific and practical conference*. Editorial EDULCP. – Buenos Aires, Argentina. 2021. P. 140 - 146. URL: <https://sci-conf.com.ua/i-mezhdunarodnaya-nauchno-prakticheskaya-konferentsiya-achievements-and-prospects-of-modern-scientific-research-11-13-yanvarya-2021-goda-buenos-ajres-argentina-arhiv/> (last accessed: 2025/02/15).